



## GEOTHERMAL WELL DRILLING

**Paul K. Ngugi**

Geothermal Development Company

P. O. Box 100746, Nairobi 00101

KENYA

*pngugi@gdc.co.ke*

### ABSTRACT

The drilling process complex as it may be rotate about breaking the ground and lifting the rock cuttings from the resulting hole. The ultimate geothermal drilling objective is to access the resource for exploitation. However, during resource development and exploitation, drilling is used to confirm existence of the resource, obtain data for resource assessment, provide adequate steam fuel for the power plant and resolve well production complications. Tri-cone tungsten carbide insert bits are very often used in geothermal drilling. Mobile and conventional land rigs are predominantly used in the geothermal drilling industry. The rigs are selected to technically fit the job at the lowest cost possible. The wells are made useful by casing them. Several casing string are used for each well. They are cemented to bond them to formation. Large production casing of 13 3/8" casing is increasing becoming common where large well outputs are encountered and directional drilling is being employed to target major faults that transmit fluids.

### 1. OVERVIEW OF THE DRILLING PROCESS

Actual breaking of ground is achieved by use of a rock bit. The bit is rotated under weight. The bit both crushes and gouges the rock as it rotates. The broken rock pieces arising from the drilling are lifted from the bore by floating them in a circulating drilling fluid. This process continues until the well is completed.

### 2. REASONS FOR DRILLING

The ultimate goal for drilling is to access the resource for exploitation. However, during the resource development and exploitation drilling serves various purposes.

#### 2.1 Exploration

The very first evaluation of a prospect is achieved through detailed surface reconnaissance. It is aimed at defining the resource by its key system characteristic namely: existence of a heat source in the form of hot magmatic body near earth surface, existence of hydrological system, characteristic of the geological setting and areal extent of the prospect (Figure 1). However, while the surface

measurement and mapping and evaluation of the surface manifestations provide great insight as regards the resource characteristics and potential, results of the reconnaissance remain inferences and are inconclusive. The initial employment of drilling in geothermal prospecting is aimed at providing proof of exploitable steam and data required for further refining of the conceptual model.

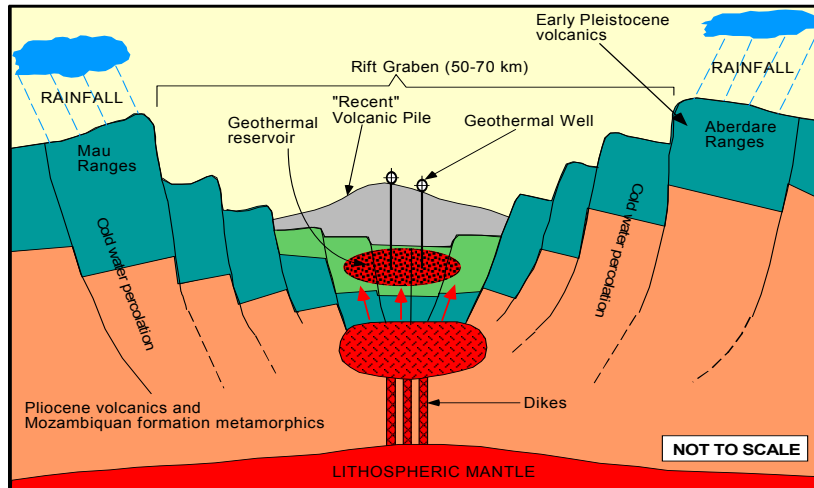

FIGURE 1: Typical conceptual model of a geothermal system in Kenya

## 2.2 Appraisal

Striking steam with the first well while is exciting opens up doors for more questions. Having confirmed existence of the resource, the next question is its technical, economic and financial viability. Further drilling (appraisal) is therefore carried out to delineate the resource and establish production well and reservoir fluids characteristics.

## 2.3 Production and re-injection

At this stage of development, a decision to construct a plant is already made. The drilling is therefore to provide sufficient steam to run the plant. Additional wells are drilled for reinjection purpose. One reinjection well is required for every 4 to 5 production wells.

## 2.4 Make-up

After commissioning of the power plant, with time the reservoir suffers pressure decline which affects well productivity. In addition, deposition may occur within the formation around the wells further reducing wells productivity. With time, therefore further drilling is carried out to replenish the reduced steam delivery.

## 2.5 Work-over

Two types of problem may arise during exploitation. Steam depletion in the shallow reservoir may necessitate deepening of the initial wells or deposition of scales within the well bore may necessitate a mechanical removal of the scales. These two cases require some form of drilling to accomplish.

## 3. BITS

### 3.1 Types of bits

#### 3.1.1 Drag bits

Drag bits is the oldest rotary tool still in use (Figure 2). The cutting blades are integrally made with the bit body. They are fixed to it and rotate as a unit with the drill string. The bit is used primarily in soft and gummy formations

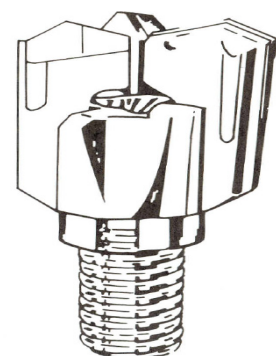

FIGURE 2: Drag bit

### 3.1.2 Polycrystalline diamond compacts (PDC) bits

The PDC bits use diamonds inserts embedded on the bit body (Figure 3). They operate by the diamonds embedding into the formation and dragged across the face of the rock in a ploughing action. The diamond bits drills according to the shear failure mechanism. They are of higher cost but their long life make them cost economic in certain circumstances. The PDC bits are used in 5% of the drilling cases in the oil industry. (Moore 1986). The bits are however hardly used in geothermal drilling.



FIGURE 3: PDC bits

### 3.1.3 Roller cutting bit

More than 95% of the oilfield footage is drilled today with tri-cone roller bits (Figure 4). This will form the basis of our discussions.

### 3.2 Description-working mechanism

Rotary bits drill the formation using primarily two principles; 1) rock removal by exceeding its shear strength and; 2) removal by exceeding the compressive strength (Adams 1985). The broken rock chips are removed by scraping or hydraulic cleaning.



FIGURE 4: Tri-cone roller bits

Shear failure involves the use of the bit tooth shearing, or cutting, the rock into small pieces so it can be removed from the area below the rock bit. The simple action of forcing the tooth into the formation creates some shearing and results in cuttings development. In addition, if the tooth is dragged across the rock after its insertion, the effectiveness of the shearing action will increase. Shear failure mechanism requires that the formation exhibit low compressive strength that will allow the insertion of the tooth. The mechanism is employed while drilling softer formations (Adams 1985).

As the compressive strength or abrasiveness of the formation increases, the shearing – twisting is reduced. The rock with high compressive strengths generally prevents the insertion of the tooth that would have initiated the shearing action. In addition, rocks with a high abrasiveness wear the bit tooth if it is twisted or dragged across the formation face. These types of rocks generally require that a compressive failure mechanism to be used.

Compressive failure of a rock segment requires that a load be placed on the rock that exceed the compressive strength for that given rock type. The load must remain, or dwell on the surface long enough for rock failure to occur. This is the basis for hard-rock drilling characteristics of high bit weight and low rotary speeds.

### 3.3 Key design features of the tri-cone bits

Roller cones bits have three components groups; the rolling cones, the bearings and the bit body (Figures 5, 6 and 7). The body is a forged and welded structure, initially having three pieces, called the legs, with bearings pins on the lower end of each leg. Each leg also has a nozzle boss and a one third circular arc-shaped piece at the top. After welding and turning, these three arc-shaped pieces form the API thread pin connection.

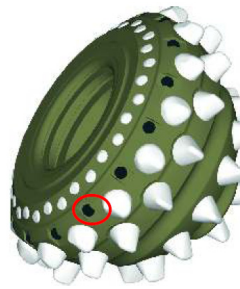

FIGURE 5:  
Bit cone



FIGURE 6:  
Bit bearing

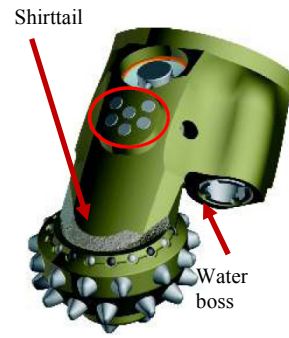

FIGURE 7: Bit body  
(single leg) with cone and  
bearing in place

### 3.3.1 Cones

Cones bearing axis are designed with an offset from the bit geometric centre (Figure 8). Ordinarily one would imagine that the bits roll on the hole bottom surface as the bit is turned. However, due to the offset, the cones tend to drag across the surface of the formation resulting in sliding, tearing or shearing, gouging and ripping action by the teeth on the bottom which help remove chips faster and more efficiently. For softer-formation, the offset is increased and therefore increase the ripping action. This means faster drilling with softer formations. As harder rocks are drilled, the degree of offset for various bits decreases since compressive failure becomes the primary drilling mechanism instead of shearing. Too much offset would cause the bit to wear quickly in hard formations.

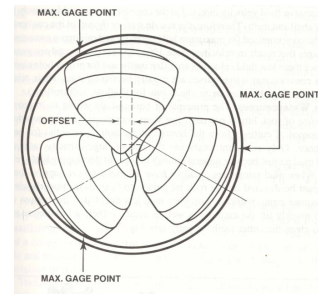

FIGURE 8: Cone offset  
(Adams 1985)

### 3.3.2 Teeth

Two types of teeth exist namely the “mill steel tooth” bit and the tungsten carbide insert bits (TCI). Under hard, abrasive rocks environment, the milled steel tooth bits are not recommended as they would wear more rapidly. Tungsten carbide insert bits are more appropriate as they are made of more wear-resistant materials.

The type of failure mechanism influences bit and tooth design and bit selection. Soft formations drilled with shearing actions are drilled most effectively with long tooth, while harder formations require more numerous, shorter teeth (Figure 9). Insert bits use tungsten carbide buttons pressed into the cone rather than milled, steel teeth.



FIGURE 9: Typical tungsten inserts profiles

### 3.3.3 Bearings

Roller bits bearings are manufactured in one of three configurations and usually use ball bearing retainers; unsealed roller bearing, sealed roller bearing and sealed journal bearing

Unsealed bearing, initially grease filled, is exposed to drilling fluids. Failure rate is high due to increase wear as a results cuttings etc. contacting with the bearing surfaces. Sealed and self lubricating journal bearing are the premium design both for the steel tooth and TCI bits.

### 3.3.4 Gauge protections

The lower exterior section of the bit leg is the “shirttail”. This area is an important part of the bit because it is the only part of the body section that contacts the formation and therefore is subject to abrasive wear. The shirttail is often protected from wear by inserting tungsten carbide inserts (Figure 7 and 9) or applying sintered tungsten carbide. Wear in the shirttail area often indicates an under gauge hole that will give future problems when running a new, full gauge bit

### 3.3.5 Water ways

An important part of the rock bit is the watercourse, without which the rest of the rock bit could not function as intended. Watercourses are passageways for the circulating fluid (Figure 7), which primarily brings cuttings to the surface and cleans the formation below the bit. The watercourse are either designed to direct the force of the drilling fluid to the cuttings to clean them from adhering materials and thus enhance drilling rate or directed at the hole bottom to quickly remove cuttings as hole bottom as soon as they are cut to improve bit drilling performance.

## 3.4 Roller cone bits classification

The drilling industry has adopted the international Association of Drilling Contractors classification as the standard in the industry (Appendix A). The System uses a three-digit code for classification which appears as follows:

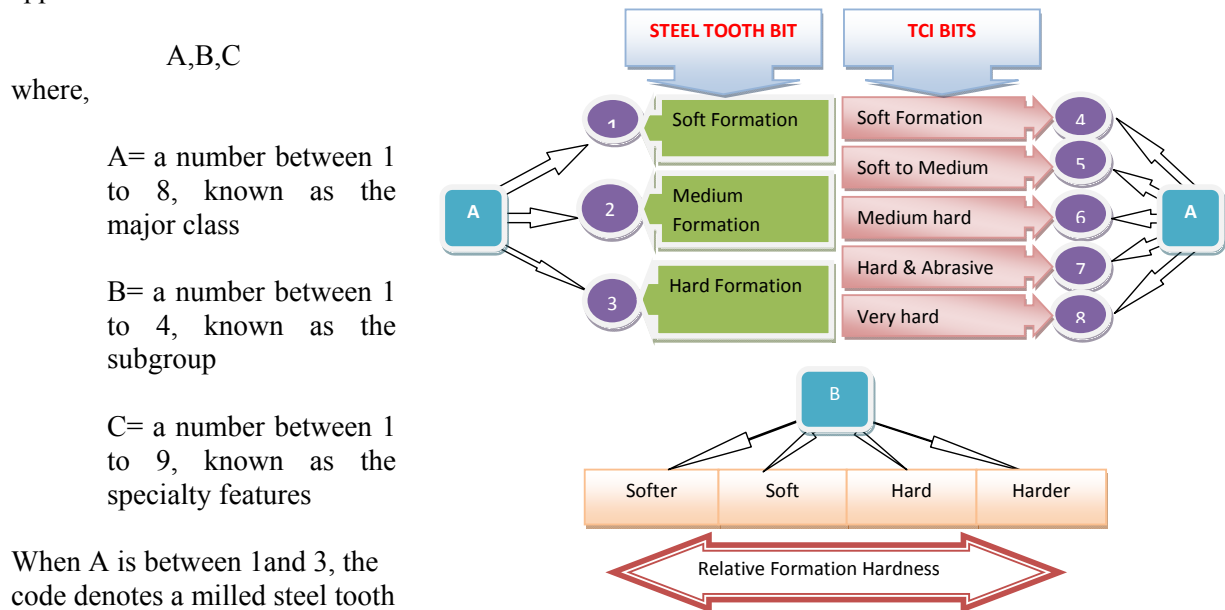

When A is between 1 and 3, the code denotes a milled steel tooth bit (Figure 10).

FIGURE 10: Bit Classification

### 3.5 Bit selection

Bit selection can be a very complex procedure if all the factors quoted by manufacturers were to be evaluated. The following is a simple guide to bit selection:

- Determine the likely formation hardness and abrasiveness
- Determine the bit size. Note that though the classification chart may show existence of a bit in a certain class, the size of bit you require may not be a common off self bit. Note also that the selected bit must easily go through the previous casing string.
- Bit economics. There exists a formula for use to determine most economical bit in an area.
- Classification chart is a good starting point (Appendix A)



### 3.6 Failure pattern

Bits failure mainly arises from the key design features discussed above.

- The cones could dislodge and be left in the hole. Good drillers would notice this by increased torque. In addition, the cones could also lock again generating high torque.
- The teeth could wear out or break rendering the bit performance poor
- The bearings could burn out resulting to very loose cones
- The bit shirrtail could wear down resulting in under gauge hole

### 3.7 Bit records

Performance of various bits within a certain region is captured through proper bit records. Analysis of the bit records (Appendix B) would give bits that give long life under the drilling conditions prevalent in that region

## 4. DRILL STRING

For the bit to perform as noted above, it requires the rotary motion, water for cleaning the bit and hole bottom and the force (weight) to crash the rocks. The drill string (Figure 11) serves to provide essential requirement for the bit to perform. The drill string is therefore an essential part of the rotary process. It is the connection between the rig and the bit.

### 4.1 Purpose

The drill string serves several general purposes including the following:

- Provide the fluid conduits to the drill bit
- Impart rotary motion to the drill bit
- Provide and allow weight (force) to be set on the bit
- Lower and raise the bit

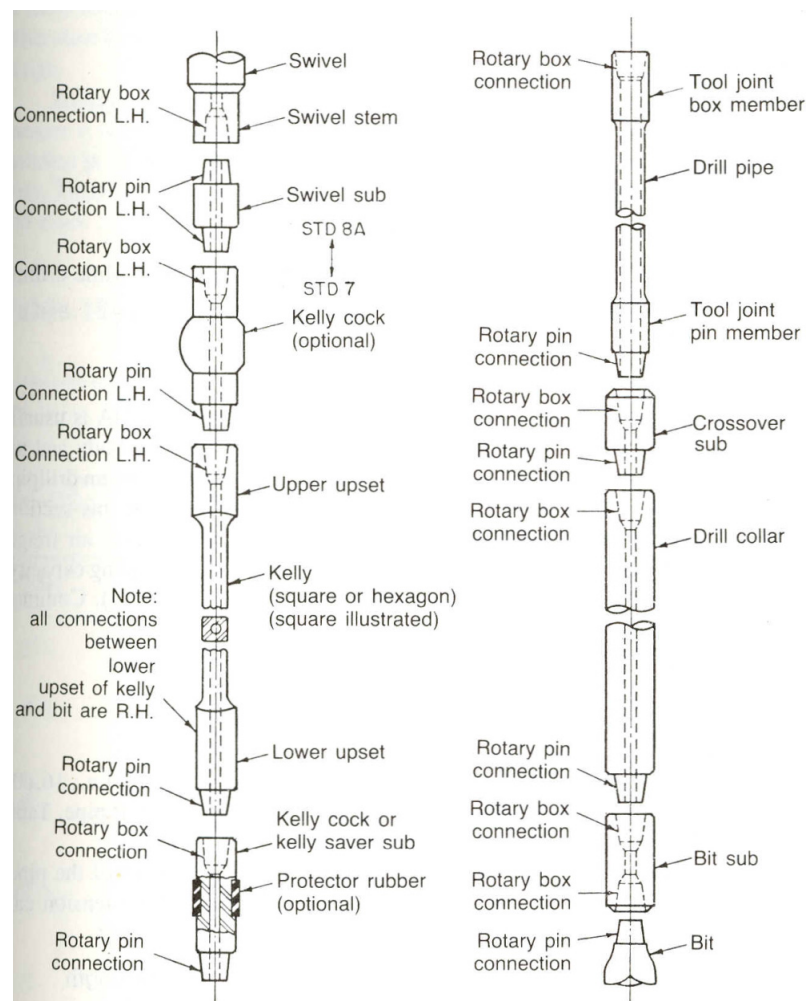

FIGURE 11: Components of the drill string

## 4.2 Components and descriptions

### 4.2.1 Bit sub / NRV sub

Immediately above the bit is fitted a bit sub and may double as non-return valve (NRV) sub. The sub is a piece of metal with a hole having female (box) thread on both sides which is about 0.3 m (foot) to 1 m (three feet) long. It is used to connect the bit and the first collar. In addition, it could have a recess to accommodate a non-return valve. The non return valve ensures that fluid do not flow back through the string to the rig floor. This especially is very important in geothermal because the fluids could be dangerously hot for staff work at the rig floor.

### 4.2.2 Drill collar

Drill collars (Figure 12) are fitted immediately above the bit sub. They are stiff steel components of about 10 m long weighing 2 to 3.5 ton. The most common sizes of collars are 6" to 10" diameter. Their functions are:

- Provide weight for the bit
- Provide strength needed to run in compression
- Minimize bit stability problems from vibrations, wobbling, and jumping
- Minimize directional control problems by providing stiffness to the bottom hole assembly (BHA)

Drill collars are available in sizes and shapes such as round, square, triangular and spiral grooved. The most common are round (slick) and spiral grooved.

### 4.2.3 Heavyweight

One problem faced by running stiff collars in the hole is that as the string rotates, the more flexible drillpipes above if fitted directly above the collar will suffer bending stresses resulting to pipe failure. The heavy weight drillpipe (Figure 13) having 2-3 times the weight of drillpipe offer a safer transition and minimize drillpipe failure.

### 4.2.4 Drillpipes

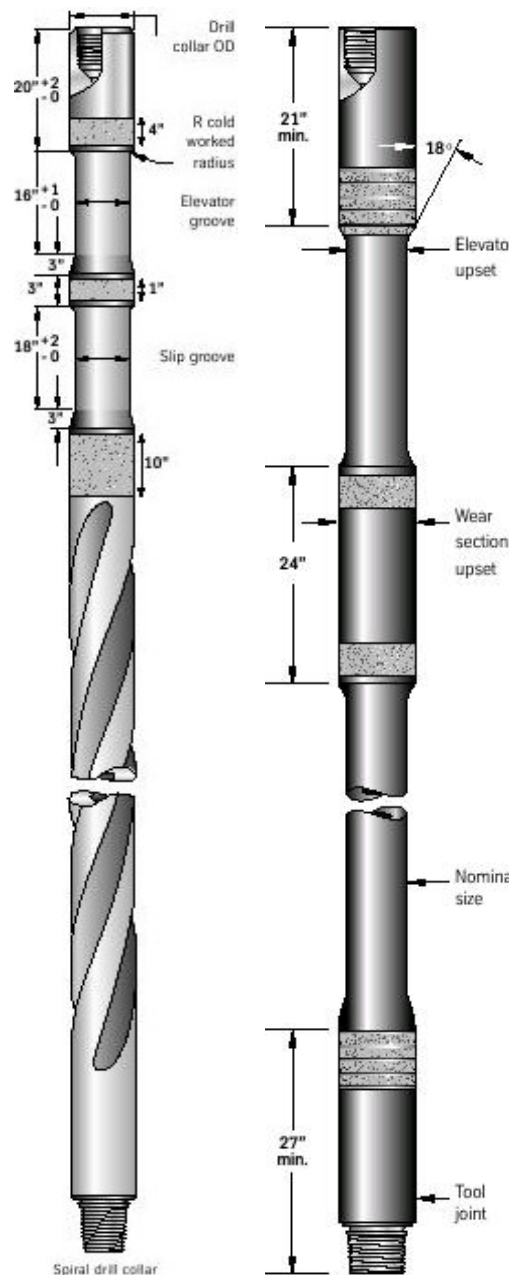

FIGURE 12: Drill collar

FIGURE 13: Heavy weight drill pipe



FIGURE 14: Drill pipe

The drillpipes (Figure 14) are the longest section of the drillstring. They consist of a tube body welded to two tools joints with male (pin) and female (box) threads. The most common sizes are 3 ½, 4 ½ and 5" diameter drill pipes.

#### 4.2.5 Kelly saver sub

In general the Kelly saver sub is fitted between the Kelly and drillpipe. It is a sacrificial tool to save the Kelly from wear arising from frequent connections.

#### 4.2.6 Kelly

Kelly (figure 15) is a very important component of the drill string. It designed in a square or hexagonal shape. It is fitted into a Kelly drive bushing (Figure 16). The drive bushing has pins that slot into the rotary table. As the rotary table rotates, the drive bushing rotating with it imparting the rotary motion to the string which is then transmitted by the string to the bit. Note for top drive the Kelly is not required.

#### 4.3 Key Design consideration

- The string must withstand the pull (tension) of its own weight. Well have been drilled to about 5000m. The total string weight may go to over 150 tons inclusive of drag.
- Besides it own weight, the design must have a safety reserve margin of about 50 tons (over pull) above the string weight which becomes necessary to free the string if stuck in the hole
- The string must withstand the force of pressure arising from the formation or drilling fluid i.e. should not collapse due to external pressure or burst due internal fluid pressure.

#### 4.4 Common string failure

The most common downhole failure is fatigue failure. As the pipe rotates in the hole it subjected to cyclic stress in crooked hole. Over time part of the string develops cracks which propagate to twist offs. The weakest point in the strings is the drill collar and drillpipe tool joints. Other failures are tool joint washouts, bellings and thread and tool joint shoulder damage.

#### 4.5 Drill string management

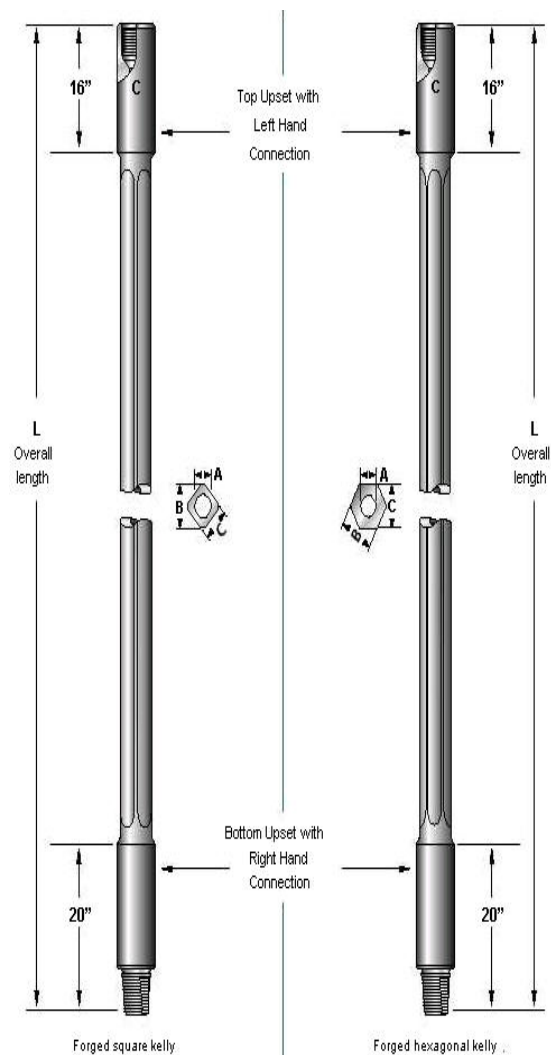

FIGURE 15: Square and hexagonal Kellys



FIGURE 16: Kelly fitted into a drive bushing



Most of the failures can be prevented or be avoided with proper care of the string. The care includes:

- Frequent string inspection. In Kenya, the string is inspected at least once every three wells drilled. In some other countries inspection is carried out after drilling every well.
- Use of thread protectors will eliminate thread and shoulder damage
- Proper torquing will eliminate over torquing, belling, and washouts
- Proper use of the right lubricants will eliminate thread galling (abnormal wear)
- Proper storage and transportation will eliminate bending

## 5. DRILLING FLUIDS

### 5.1 Purpose of drilling fluids

Primarily, the drilling fluid function is to remove the cuttings from the bottom of the hole as fast as they are created to facilitate further and efficient hole making process. In addition, the fluid transports the cuttings to surface. The two functions constitute what is normally referred as hole cleaning. The drilling fluid in real drilling situation is a complex subject with consideration ranging from the basic hole cleaning, economics, availability, logistics, chemistry, safety, fluid dynamics and reservoir management. As such the drilling fluids serve many functions.

The major functions include;

- Cleaning of the hole bottom,
- Carry cuttings to the surface
- Cool and lubricate the bit and drillstring
- Remove cuttings from muds at the surface
- Minimize formation damage
- Control formation pressure
- Maintain hole integrity
- Assist in well logging operations
- Minimize corrosion of drillstring and casing
- Minimize contamination problems
- Minimize torque, drag and pipe sticking
- Improve drilling rate
- Cooling of the formation – unique for geothermal

### 5.2 Types of drilling fluids

The drilling fluids vary widely. The following table gives a classification of drilling fluids (Chilingarian, 1983)

- I. Water based drilling fluid.
  - a. Fresh water muds with little or no treatment. This include spud mud, inhibited muds and natural clays
  - b. Chemical treated muds without calcium compounds added. This includes phosphate muds, organic treated muds (lignite, chrome-lignosulfonate etc.)
  - c. Calcium treated muds which include lime, calcium chloride and gypsum
  - d. Salt-water muds which include sea water muds, saturated salt water muds
  - e. Oil emulsion muds i.e. oil in water
  - f. Special muds
- II. Oil based drilling muds
  - a. Oil based muds

- b. Inverted emulsion muds – water in oil

### III. Gaseous drilling fluids

- a. Air or natural gas
- b. Aerated muds
- c. Foams

## 5.3 Key drilling fluid properties

The three basic properties of drilling fluids that are mostly important for successful completion of a well are:

- a) Density as related to hydrostatic pressure.
- b) Viscosity which affects the efficiency of the cutting lifting capacity of the drilling fluid
- c) Filtrate loss – the loss of water component of the drilling fluid into formation

## 5.4 KenGen drilling fluid practice

### 5.4.1 26” Surface hole

The first section of the well is commenced with spud mud consisting of bentonite – lime with marsh funnel viscosity of 60-80 sec marsh funnel viscosity and is drilled to 60 m.

If return circulation is lost and cannot be regained with loss control materials (LCM), drilling continues blind (without circulation to surface) with water and high viscosity gel sweeps at every connection or more frequently depending on the hole problems.

### 5.4.2 17 ½” intermediate hole

This section of well is drilled to a depth of about 250 to 300m with a bentonite –lime mud. If loss of circulation returns occurs, attempts are made to regain it using LCM. If the loss cannot be healed, drilling continues blind with water and frequently mud slug of high viscosity mud. The section is drilled with high pumping rates on the hole to clean the hole. In extreme circumstance of poor cleaning stiff foam is used.

### 5.4.3 12 ¼” production hole

This section that is drilled to between 500 to 1200 m is drilled with mud and when mud circulation cannot be sustained, aerated water with foam is used.

### 5.4.4 8 ½” main hole

This section that is drilled normally to 2200 m to 3000 m is entirely drilled with water and when the first signs of lost circulation appear, partial or total, aerated water with foam is used. No mud is ever introduced to this section for protection of the formation. However, in one of our field, Olkaria West, we have used aerated mud for this section due to severe sloughing problems. The in-going fluid is maintained at a maximum temperature of 40°C, which is the maximum recommended operating temperature for the pumps. Control of temperature is also critical for extending the bit life.

## 6. DRILLING RIGS

### 6.1 Basic functions

From a basic and simplistic view, the rig can be seen as that equipment that provides the motive power to rotate the bit, allow weight on the bit to crush the rock beneath and circulate the drilling fluid and hence achieve the drilling action. Achievement of these basic rig functions requires systems and processes where various individual pieces of equipment serve only as part of the function in the whole process and system. Operational requirements and economics dictate the sophistication of drilling rigs.

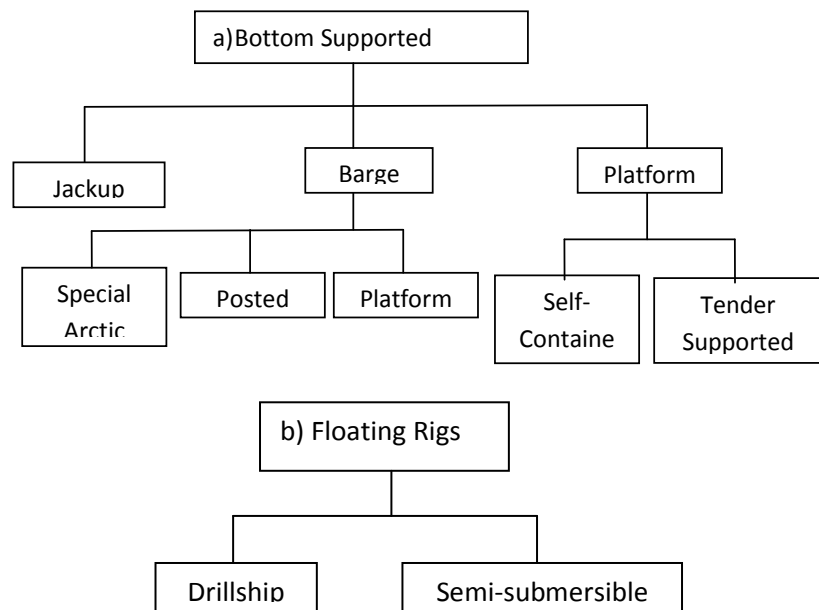

FIGURE 17: Classification of Marine rigs

### 6.2 Types of rigs

All rigs are categorized as either land or marine. Each of these categories, comprise various types of drilling rigs.

#### 6.2.1 Marine rigs

Drilling rigs used offshore (in water) are termed marine rigs. They fall under two categories; those supported on water bottom and floating vessels (Figure 17). Figure 18 shows one type of marine rig.

The marine rigs are not employed in drilling of the geothermal wells.

#### 6.2.2 Land rigs

The land rigs fall under two main categories; the cable tools and the rotary rigs. The cable tools accomplish the drilling action by raising a special drill bit and dropping it. The cable tools are the predecessor of the modern rotary rigs and are hardly used anymore.

The rotary rigs fall under three categories:

- a) The standard derrick where the mast/derrick was built on location and dismantled after the drilling process. These were the very early rotary rigs



FIGURE 18: Jack-up marine rig



FIGURE 19: Mobile land rig

- b) Portable rig mostly truck-mounted for low rig up time (Figure 19).
- c) Conventional rig where key components are so large that they cannot be transported on a single truck bed (Figure 20).

**6.3 Rig equipment systems**

The rig (Appendix C) has six distinct systems:

- Power system
- Hoisting System
- Circulating System
- Rotary system
- BOP System
- Auxiliary Rig equipments



FIGURE 20: Typical conventional rig

**6.3.1 Power system**

The power system consists of a prime mover, primarily diesel engines, and some means of transmitting the power to the auxiliary equipment. Transmission may be in the form of mechanical drives like chains, DC generators and motors or AC generators, SCR (Silicon control rectifiers), Dc motors

**6.3.2 Hoisting system**

The hoisting system is one of the major components of the rig. Its primary function is to support, lift and lower rotating drillstring while drilling is in progress. It consists of:

- i) Supporting structure: The support structure includes the mast or derrick, the substructure and the rig floor
- ii) The hoisting equipment: This includes the drawworks, crownblock, travelling block, hook, links, elevators and the drilling wire-line

**6.3.3 Circulation system**

The circulation system (Figure 21) is another major component of the rig affecting its overall success. Its main purposes are stated under the drilling fluid section above. It consists of pumps, standpipe, rotary hose, swivel, Kelly, drillstring, shale shakers, tanks and mud pits.

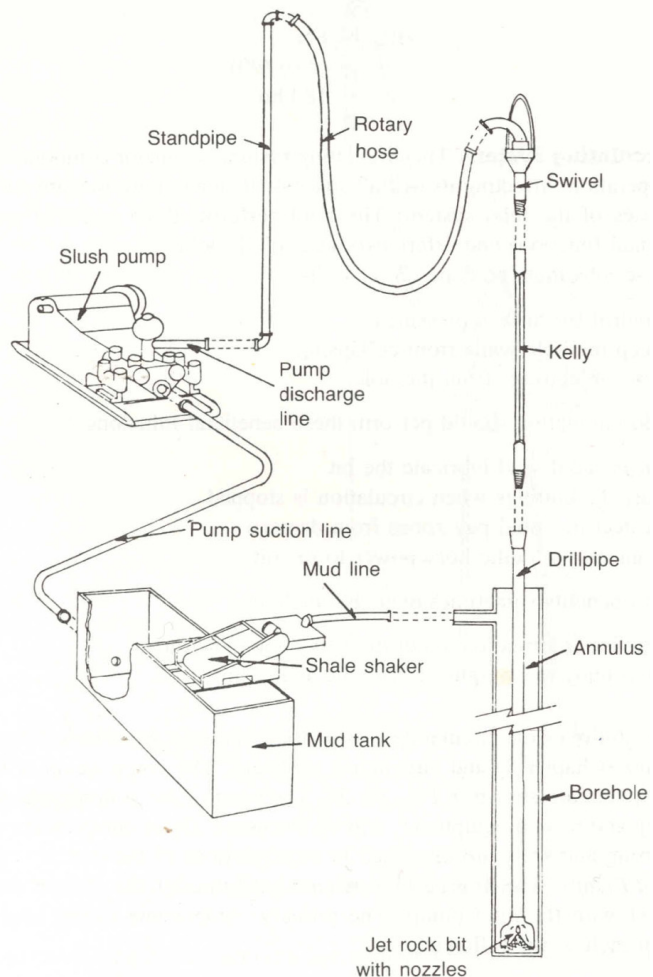

FIGURE 21: Typical fluid circulation system



### 6.3.4 Rotary system

The rotary system is responsible for imparting a rotating action to the drillstring and bit. The principle components are the Kelly, rotary table and drive bushing, swivel rotary hose and drillstring.

### 6.3.5 BOP system

The blowout preventer (BOP) are primarily used to seal the well to prevent uncontrolled flow, or blowout, of formation fluids. Typically it consists of annular BOP (Figure 22), drillpipe or casing ram BOP, blind ram BOP and accumulator system



FIGURE 22: Two BOP stack

### 6.3.6 Auxiliary rig equipment

The auxiliary rig equipments are those items of the equipment that added to the drawworks, rotary, Kelly, swivel, blocks, drilling line, bits and prime movers, make it possible for the rig to function more efficiently. The can be broadly be groups as:

- Drillstring handling tools; spinning wrenches, power tongs, hydraulic torque wrenches, power slips, automatic drilling, Kelly spinner, automatic cathead
- Instrumentation; weight indicators, mud pumps pressure gauge, rotary tachometer, rotary torque gauge indicator, pump stroke indicator, tong torque indicator, rate of penetration recorder
- Air hoist
- Rig floor tools

## 6.4 Rig selection

Rig Selection comes as the last activity after the complete well design i.e. after setting the drilling depth, casing sizes, weights and casing depths, the drilling fluid and hydraulic power requirements. The key considerations are to select a rig that will be technically adequate for job and at minimum cost. In addition, qualifications of the rig's manpower and its performance track records, logistics of servicing the rigs and rig-site requirements are also considered. Table 1 shows typical rig sizes.

TABLE 1: Typical Rig Sizes (Composite catalog, 1998-1999)

Drawworks Hoisting Power rating		Typical Depth Rating		Maximum Hoist Capacity (Hook Load)									
				6 lines		8 lines		10 lines		12 lines		14 lines	
hp	kw	ft	m	lb	ton	lb	ton	lb	ton	lb	ton	lb	ton
550	410	3,000 to 8,500	914 to 2,591	236,000	107	302,800	137	364,500	165				
750	559	7,000 to 12,000	2,134 to 3,658	314,200	143	403,100	183	485,300	220				
1000	746	10,000 to 14,500	3,048 to 4,420			437,300	198	526,700	239	609,500	277		
1500	1,119	12,000 to 18,000	3,658 to 5,486					708,100	321	819,300	372	922,900	419
2,000	1,864	13,000 to 25,000	3,962 to 7,620					919,200	417	1,064,100	483	1,198,600	544
3,000	2,237	16,000 to 30,000	4,877 to 9,144							1,484,360	673	1,671,960	756

## 7. WELL PLANNING & CASING DESIGN

### 7.1 Objective of well plan

The main objective of planning a well is to drill safely, minimize costs and drill usable well.

### 7.2 Classification of wells

Wells can be categorized as follows:

- |                               |  |
|-------------------------------|--|
| • Exploration/discovery wells | No geological data or previous drilling records exist                    |
| • Appraisal wells             | Delineates the reservoir's boundary; drilled after the exploration wells |
| • Production wells            | Drill the known productive portions of the reservoir                     |
| • Work-over wells             | Re-entry of already drilled wells to deepen, clean etc.                  |

Planning for the drilling of exploration wells takes more effort than appraisal wells and production drilling. This is because the discovery wells are drilled in unknown area thus the unexpected can happen.

### 7.3 Purpose of casing

The target resource is found for Kenya from around 500m to as deep as 3000m. The wells are cased for the following reasons:

- Isolate fresh underground water to prevent contamination
- Maintain the hole integrity by preventing caving in to enable drilling further below
- Minimize lost circulation into shallow permeable zone
- Cover weak zones that are incompetent to control kick-imposed pressure (prevent blowouts)
- Provide a means for attaching and anchoring BOP and wellheads and thereby contain resultant pressures.

- Provide safe conduit for the reservoir fluids to the surface
- To prevent cooling of the reservoir fluids by shallow cooler fluids
- Prevent well collapse

#### 7.4 Categories of casing strings

Before the well is drilled to completion, several strings of casing are run and cemented in place. The actual number used is depended on the drilling safety and operational problems anticipated or encountered. The types of casing strings are:

- Surface casing: Mainly used to isolate the shallow loose formation to enable further trouble free drilling below.
- Intermediate casing: This may be more than one string. They primarily isolate the shallow potable water from contamination, provide anchorage for the wellhead and seal off zones of loss of drilling fluid. They also protect the shallow formation from high downhole pressure thus prevent blowouts.
- Production casing: This primarily act as the safe conduit for the reservoir fluid to surface, protect shallow formation from deep reservoir pressure thus prevent blowouts and isolate cooler shall water from degrading the reservoir fluids
- Slotted liner: This is primarily run to prevent the reservoir wellbore from collapsing and blocking the well flow path.

#### 7.5 Selecting casing depths

The first design task in preparing the well plan is selecting the depths to which the casing will be run and cement. The considerations made are the geological conditions such as formation pressures and formation fracture gradient. Other considerations are policy and government regulations. Wells have been drilled and cased too shallow or too deep.

#### 7.6 Hole geometry (well casing profile)

Having decided on the casing depth, the next design aspect is to decide on the casing string sizes to be run in the hole. Figure 23 shows the typical casing profile within KenGen. The key consideration at this point is well productivity versus costs. Small well bore may choke the well thus rendering it unproductive while on the other side large wellbore cost much more. The drilling industry has developed several commonly used geometries (Appendix D). These programs are based on bit and casings availability as well as the expected drilling conditions. The most common casing geometry employed in geothermal is:

- 20" Diameter casing for 26" diameter surface hole
- 13 3/8" diameter casing for 17 1/2" diameter intermediate hole

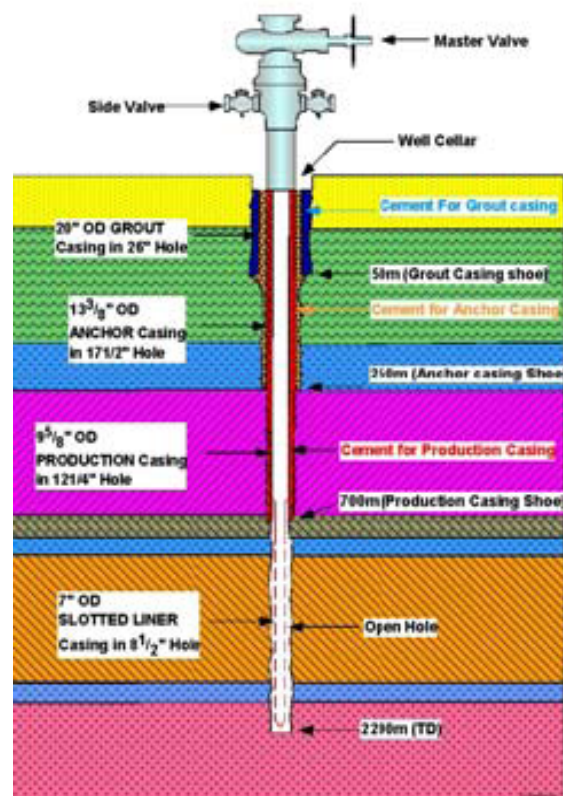

FIGURE 23: Typical well in Kenya

- 9 5/8" casing for the 12 1/4" production hole
- 7" slotted liner for the 8 1/2" main hole

The considerations made are casing inner and outer diameter, coupling (collar) diameter and bit sizes.

Sufficient allowance is made to allow flow area between the casing and wellbore to reduce washouts while provide sufficient velocity for drilling fluid to lift cuttings.

**7.7 Casing design**

The casing is used for protection during the entire life of the well and therefore it is designed to withstand many severe operating conditions.

Common problems often considered for casing design when drilling are kicks, lost circulation, stuck pipe, wear, hydrogen sulphide environment and salt. Just like the drilling string, the casing is designed to withstand burst, collapse, tension forces and biaxial effects (combined effects).

In General the thicker the casing the more resistance it is to the above factors. However, the more the well cost.

**8. CEMENTING**

**8.1 Purpose**

Cementing of casings is one of the critical operations during the drilling of a well that affects the producing life of a well. Casing strings are usually cemented in the hole to:

- Bond the casing to the formation
- Protect deeper hot producing zones from being cooled by cooler water emanating shallow bearing zones
- Minimize the danger of blowouts from deeper high pressure zones by isolating weaker shallow zones
- To isolate shallow troublesome formation to enable deeper drilling

**8.2 Surface and subsurface casing equipment**

Figure 24 (Smith, 1976) shows the key equipment used in casing cementing. Their basic functions are summarized as follows:

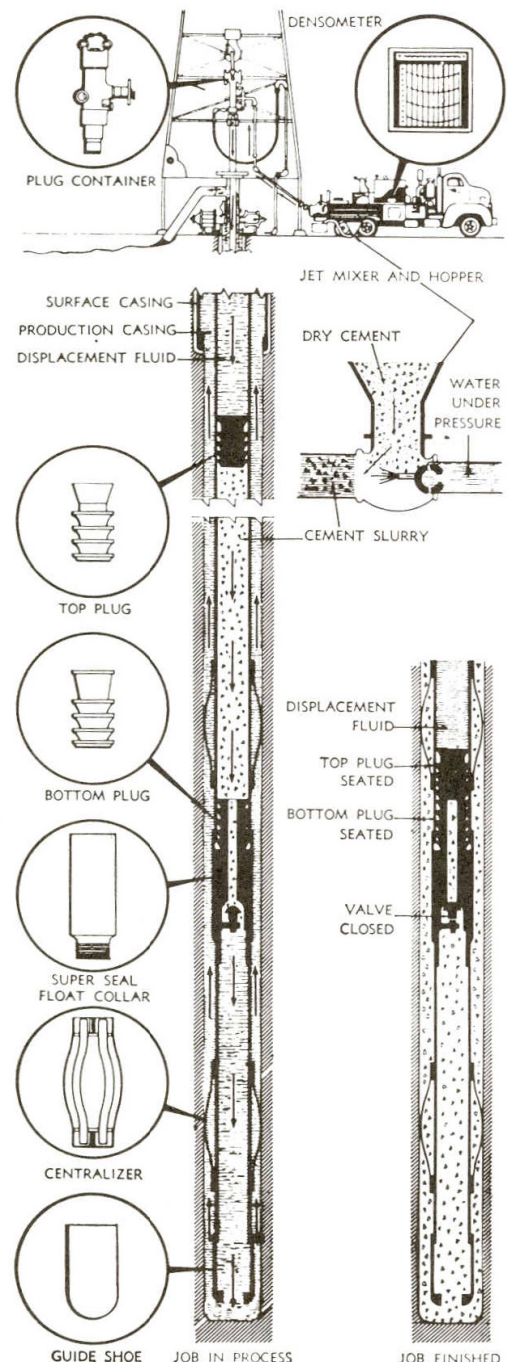

FIGURE 24: Typical primary cementing job



### 8.2.1 Guide shoe

A casing shoe joint is a short pipe run on the casing bottom. Inside of the pipe is packed with drillable but hard material shaped in a rounded nose provided with a hole which is used to guide the casing into the hole through crooked sections. The shoe is screwed on the casing and is glued with a thread locking compound to avoid inadvertent loosening while being run in the hole.

### 8.2.2 Float collar

The float collar is placed one or two casing joints above the guide shoe. The collar serves as a stop for the cement wiper plug such that all the cement is not inadvertently pumped out of the casing and diluting the cement at the shoe a situation that would result to a poor cementing job. It is fitted with a ball or spring-loaded backpressure valve. The valve prevents well bore fluid entering the casing while allowing pumped fluid through the casing to pass through.

### 8.2.3 Casing centralizers

The uniformity of the cement sheath around the pipe determines to a great extent the effectiveness of the seal between the wellbore and the casing. Centralizers are placed on the exterior of the casing string to centralize the casings within the wellbore in an effort to attain cement around the casing in the whole string. There are several types of centralizers with the bow spring type being the most common. The centralizers are normally hinged to aid in fitting them round the casing.

### 8.2.4 Cementing plugs

Drillable Plugs are used to separate cement and water/mud while displacing cement within the casing.

### 8.2.5 Cementing head

Cementing heads are containers for the cement plugs. The plugs are retained until when the cement pumping is over and then released. They are also used as connections of the fluid hoses from the pumps and the top of casing.

## 8.3 Primary cementing procedure

Primary cementing is the most important of all cement Jobs. It is performed immediately after the casing is run into the hole. The objective is to deliver quality cement behind the casing that is the annulus between the casing and the formation or previous casing strings. Two methods are normally employed for the primary cement job namely the conventional and stub-in (stinger) method.

The conventional method could be single or multiple stage technique. In the single stage cementing technique, cement slurry is mixed in the pumping truck and the cement slurry pumped inside the casing string through the cementing head. After the entire slurry volume has been pumped, the cement slurry within the casing is displaced to the float collar using water. The two are separated by use of cementing plugs (top). The cement is prevented from flowing back by the ball valve fitted on the casing float collar or casing float shoe or using a valve fitted to the cementing head.

After landing casing and before commencing pumping cement slurry, a drilling fluid is circulated in the hole. The purpose of the drilling fluid is:

- To ensure the flow path is clear. Several factors can cause blockage of the fluid path way. These are cuttings, sloughing/ collapsing formation, boulders or the casing could seat on the hole bottom if not properly landed.

- To clean the well. If hole cleaning problems had been experienced previous to running the casing, then a high viscous mud would be pumped to lift the cuttings from the hole bottom
- To cool the well bore. Cement setting is affected by high temperature. In severe situations the cement can set instantly on contact with steam stopping any further cement flow leading to failed cementing job. Cold water is normally circulated at least for 30 minutes before commencing cementing.
- To scrap of mud wall cakes.

#### **8.4 Factors that influence slurry design**

There are many factors considered in primary cement job slurry design. The key ones include the well depth, well bore temperature, pumping time, slurry density, strength of cement required to support the pipe, lost circulation, filtrate loss and quality of mixing water.

The mixing water should be clean for the resulting slurry to develop the desired properties in particular strength. Deep wells require fairly long time to carry out and complete the cementing jobs. This means that the cement slurry must remain pumpable for the entire period during the cementing job. Temperature and pressure accelerates the setting of cement slurry. Therefore it is very important to take into consideration the effects of these parameters. Major losses of cement can result to very expensive jobs both on lost cement and operation time. The density of the slurry is designed to effectively control blowouts and to displace mud from the well bore.

#### **8.5 Cementing additives**

The desired properties for a specific cement slurry design are achieved by adding various chemicals and materials (additives) that alter the ordinary Portland cement normal behaviour. The additives are classified as follows:

- i. Accelerators
- ii. Lightweight materials
- iii. Heavy weight materials
- iv. Retarders
- v. Lost circulation control materials
- vi. Filtration- control agents
- vii. Friction reducers and
- viii. Specialty materials

Accelerators are used to shorten the cementing thickening time, light weight additives are added to the slurry to reduce the slurry density while the heavy weight additives are added to increase the density. The cement retarders are added to the cement to increase the slurry thickening time for long jobs while friction reducers are added to the cement slurry to improve flow properties of the slurry. The lost circulation control materials are added to the slurry to bridge minor formation fractures that would take up cement while filtration control additives are added to reduce the water loss from the slurry to the formation which would result to early thickening of the cement slurry.

#### **8.6 Open-hole plug jobs**

Cementing jobs are not limited to casing operations only. They are often times also used to plug major drilling fluid loss zones. Major fluid circulation losses results to loss of data obtained from cutting. They further results to poor hole cleaning and the rock cuttings repeatedly fall back into the well bore as soon as the pumps are stopped. The falling cuttings at time result into stack drill string. Cement slurry without additives is prepared and placed at the point where the losses are and the cement is allowed to set thereby sealing out the formation fractures.

## 9. WELL OUTPUT OPTIMIZATION

The objective of drilling a well is to obtain the maximum output from the well. Where good permeability have been encountered, it has been shown that the production casing size of 9 5/8" diameter has inhibited well output in some cases. In such fields, it is becoming increasing more common to use the 13 3/8" casing as the production casing.

It is now a common practice to drill directional wells which target faults that control fluid movement with the objective of increasing well output.

Over 60% of the well cost is incurred drilling the upper section of the well to the production casing (500 - 1500m). Drilling of forked or multi-legged well completions may become increasing common as a way to optimize investment economics.

## 10. FISHING

Fishing takes upto 20% of drilling well. Fishing is the process of removal of objects or obstructions that impedes further drilling. Each rig is equipped with some form of fishing tools. Fishing jobs require high skill and specialized equipment. Most companies find it more economic to rely on service companies to furnish the tools and specialized personnel when need arise.

## 11. MANAGEMENT OF DRILLING PROCESS

Drilling can be broken into the drilling operations that involve the actual drilling process and running of casings, cementing process, specialized drilling fluids operations, e.g. air drilling services, directional drilling services, well logging, drill pipe inspection services and sometimes rig moving services. Various contracts are drawn to avail all these services depending on the well design and anticipated drilling problems. A representative of the company is appointed to represent the client on a 24 hr basis. Other specialized requirements like fishing are obtained as and when need arise.

## REFERENCES

Adams, N.J., 1985: *Drilling Engineering, A complete Well Planning Approach*, Penn Well Publishing Company, Tulsa, Oklahoma, USA, 960pp.

Chilingarian G.V. and Vorabutr, p., 1983: *Drilling and Drilling fluids*, Updated \textbook Edition, Elsevier Science Publisher P. V., Amsterdam, The Netherlands, 801pp.

Composite catalog 1999: Continental Emsco General Catalog, *Gulf Publishing Company Publication, Houston Texas, USA, 1.*

Moore, P.L., 1986: *Drilling Practices Manual*, Second Edition, Penn Well Publishing Company, Tulsa, Oklahoma, USA, 586pp.

Smith K.D., 1976: *Cementing*, Second Printing, Millet the Printer .Inc. , Dallas, Texas, 184pp.





APPENDIX B: Bit record chart

COUNTRY: KENYA										FIELD: OUKARIA DOMES		AREA: OUKARIA		LOCATION: 20857.87E 90038.45N		WELL NO: CW4901									
CONTRACTOR: KENGEN										RIG NO: NSTO		OPERATOR: KENGEN		DRAWWORK POWER: 500 HP											
SPUD: 10TH SEPTEMBER 1998										PUMP No. 1 LINER: 7.4" - 50		PUMP No. 2 LINER: 7.4" - 50		PUMP POWER: 500 HP		MUD TYPE: WATER BASE									
DRILL PIPE: 4 1/2" 2H										TOOL JOINT		SIZE: 6 1/4"		TYPE: 6 1/4"		OD: 8.0R12		ID: 2.5316"		LENGTH: 35FT					
NO	SIZE	MAKE	TYPE	JET 32ND IN	SERIAL	DEPTH OUT	METERS	HOURS	METERS / HOUR	ACCU DRLO	WT 1000 KG	RM	VEAT DEV. (DEG)	PUMP PRESS.	PUMP OR R	SPM		MUD		DULL COND			FORMATION REMARK		
																1	2	WT	V/S	W/L	T	B		G	OTHER
1	26"	SEC.	S35J	OPEN	488226	64	64	55	1.16	86.75	2	40			90%		80	1.01			1	1	1		HARD & ROUGH
2	1/2"	SEC.	S8MF	OPEN	490556	261.4	167	56	3.52	56					90%										MED. SOFT
3	1/4"	SEC.	M85TF	OPEN	518914	406.6	248	119	2.08	117	6	80	1.92	390	90%		110		MUD & WATER		1	1	1	1/8	HARDMED
4	1/4"	SEC.	M85TF	OPEN	513078	712	225	55.5	4.06	55.5	6	80		540	90%		130		WATER		1	1	1		SOFT & ROUGH
5	1/4"	SEC.	S8MF	OPEN	523890	773.9	61.9	12	5.16	12	6	80		450	90%		130		AIR H2OFOAM						
6	1/2"	T8K	A40	OPEN	208440	888.6	215	54.45	3.94	54.45	4	90		400	90%		130		AIR H2OFOAM		1	8	18		
7	1/2"	HUGHES	A1155	OPEN	T-45-BH	927	228	63.5	3.59	63.5	4	90	2	450	90%		60		AIR H2OFOAM		2	8	4		MED. SOFT
8	1/2"	T8K	A40	OPEN	208511	1335	108	32	3.38	32	45	90		600	90%		70		AIR H2OFOAM		1	4	1		MED. SOFT
9	1/2"	T8K	K70	OPEN	206801	1594	259	67	3.87	67	4	90		690	90%		90		AIR H2OFOAM		1	6	1		MED. SOFT
10	1/2"	T8K	K70G	OPEN	206711	1662	68	23	2.96	23	5	90		700	90%		100		AIR H2OFOAM		1	4	1		MEDIUM
11	1/2"	T8K	K70G	OPEN	206731	1838	176	54.5	54.50	54.5	5	80		590	90%		100		AIR H2OFOAM		1	6	1		MEDIUM
12	1/2"	HUGHES	A1155	OPEN	T-46-BH	2105	266	74.1	3.59	74.1	6	90		1000	90%		100		AIR H2OFOAM		8	8	8		MED. HARD
13	1/2"	T8K	K70G	OPEN	206791	2200	95.4	26.5	3.60	26.5	7	90		1200	90%		100		AIR H2OFOAM		4	8	1		MED. HARD

**APPENDIX C: Description of key rig parts**

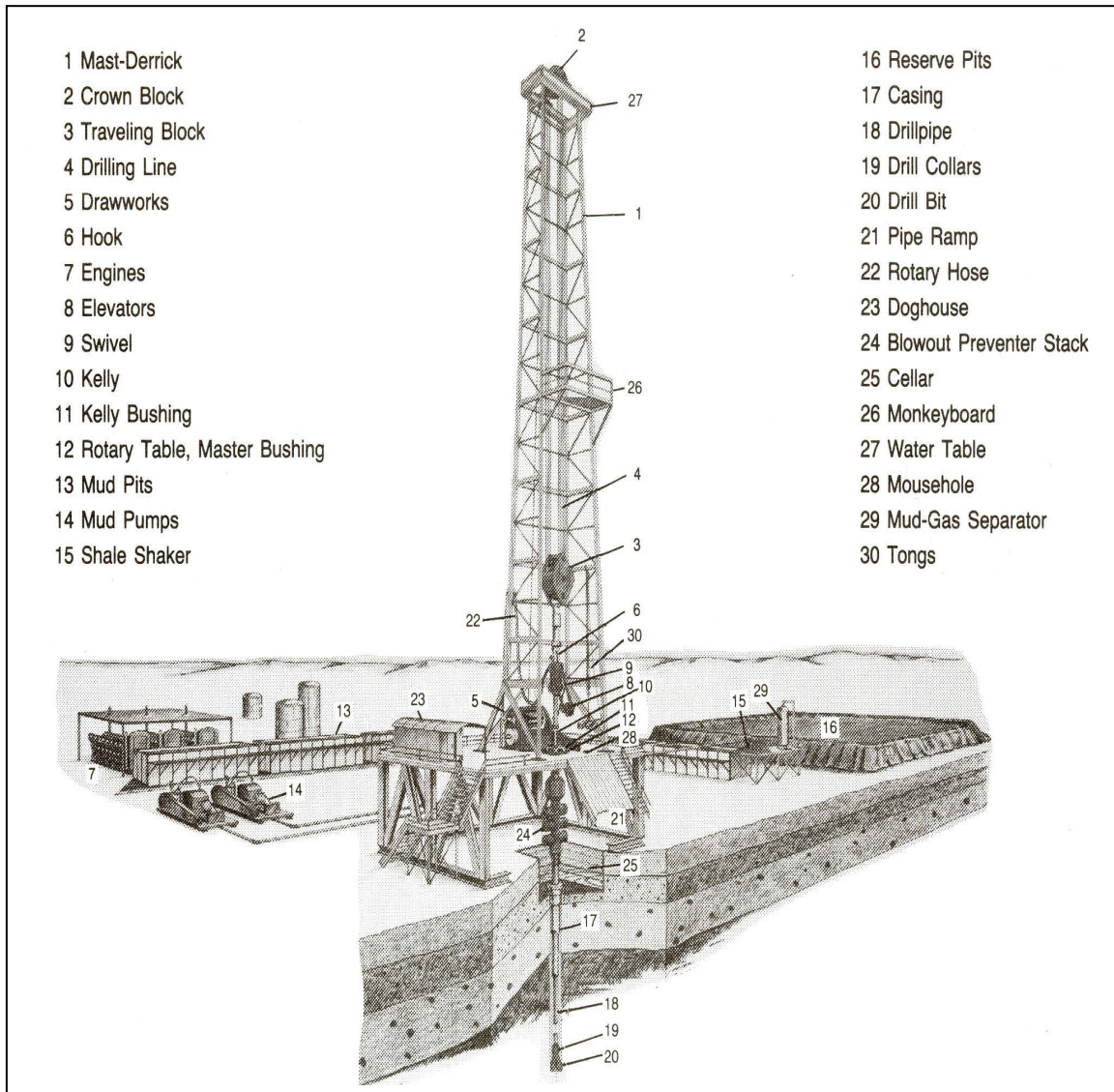

APPENDIX D: Typical bit-casing geometries

