

RESTRICTED

RIVER FORECASTING
in the
HVÍTÁ AND THJÓRSÁ RIVER BASINS
IN ICELAND

by
Josef Procházka
United Nations Special Fund
May 1966

This report has not been cleared with the Office of Special Fund Operations, Department of Economic and Social Affairs, of the United Nations, which does not therefore necessarily share the views expressed.

RIVER FORECASTING
in the
HVÍTÁ AND THJÓRSÁ RIVER BASINS
IN ICELAND

by
Josef Procházka
United Nations Special Fund
May 1966

This report has not been cleared with the Office of Special Fund Operations, Department of Economic and Social Affairs, of the United Nations, which does not therefore necessarily share the views expressed.

C O N T E N T

1	PREFACE	1
2	SUMMARY	2
3	RECOMMENDATIONS	7
3.1	Precipitation and temperature records	7
3.2	River gauging stations	9
3.3	Groundwater stage measuring	9
3.4	Methods of computations	9
4	ACCOUNT ABOUT ICELANDIC RIVER RUNOFF CONDITIONS AND RECORDS AVAILABLE, ESP. AS TO THAT OF THE HVÍTÁ AND THJÓRSÁ RIVERS	11
4.1	General hydrological description	11
4.2	The HVÍTÁ river system	14
4.3	The THJÓRSÁ river system	15
4.4	Meteorological and hydrological data relevant to the water balance and runoff forecasting	17
5	RIVER FORECASTING	19
5.1	General consideration	19
5.11	River discharges variability	21
5.12	Storage reservoirs	21
5.13	Seasonal water-supply forecasts	22
5.14	Runoff forecasting (except spring runoff)	23
5.15	Spring runoff forecasting	24
5.16	River forecasting in upper mountainous parts of basin	25
5.2	Winter runoff forecasts based on hydrological records only	26

5.21	Gullfoss' catchment area	27
	example 1	28
	example 2	29
	example 3	29
5.22	Faxi' catchment area	31
5.23	Dynjandi' catchment area	31
5.24	Conclusion	32
	example 4	32
5.3	Winter runoff forecast using both the hydrological and meteorolo- gical records	33
5.31	Temperature relations	34
5.32	Precipitation relations	35
5.33	Runoff forecast relations (for the Hvítá, Tungufljót and Brúará rivers)	35
5.34	Discussion	41
	example 5	41
	example 6	43
5.4	Conclusions	43
6	REFERENCES	45
7	LIST OF EXHIBITS ATTACHED	47
7.1	Figures	47
7.2.	Tables	49

RIVER FORECASTING IN THE HVÍTÁ AND
THJÓRSÁ RIVER BASINS IN ICELAND

1 PREFACE

This study is carried out in connection with my task, which has been formulated by the United Nations Special Fund Project in Iceland in several items, of which I may quote the following: "The expert is expected to advice the Government on the best method of forecasting flood volumes and dependable yields at project sites on the Hvítá and Thjorsá rivers".

During my stay in Iceland I had the most valuable assistance and cooperation of Mr. Jakob Gíslason, the Director-General of the State Electricity Authority, and his staff, especially of Mr. Jakob Björnsson, Mr. Sigurjón Rist and Mr. Guttormur Sigbjarnarson. I want to express my thanks and appreciation for all their assistance.

Field reconnaissance of the Hvítá and Thjorsá river basins was done by car during the winter (December 65 and January 66) in the lower parts of these basins, and by car and plane in the remaining parts (during the better weather conditions from February through April). This reconnaissance was very useful to get a good acquaintance with the feeding and runoff conditions (surface and subsurface runoff, riverbed conditions and so on) in both these basins.

The office studies (on the base of the meteorological and hydrological records and assumptions) were carried out during the whole six months' period of my stay in Reykjavík. The use of the IBM-computer helped to gain time for other needful considerations and computations. I hope that the conclusions and recommendations of this study will be of use for the solution of the river forecasting problem in Iceland.

Reykjavík, May 1966



Josef Procházka

2 SUMMARY

This study is devoted to the discharged volume forecasting within the Iceland's most power potential river catchment areas, namely that of the Hvítá and Thjorsá rivers. The hydro power generation seems to be by far the most important economic activity in Icelandic rivers, the freshwater fishery being the single but weak competitor of it.

The United Nations Special Fund Project in Iceland for development of the Hvítá and Thjorsá river basins provides that a range of water power plants, storage reservoirs and supplementary constructions will be put up. It is supposed that the harnessable volume of the four or five storage reservoirs planned would be in use during the period of lower river feeding to increase the powerplant production. Therefore the suitable, sufficiently exact and saving methods of forecasts-making are required especially as to seasonal or middle-term forecasts of discharged volumes during winter. This kind of forecast may improve the reliability and value of the water power plant production working plans, that used to be carried out in advance for the storage reservoirs exploitation periods.

The short-term forecast of discharges or water level stages is of little use in Icelandic weather conditions with regard to the relatively short lengths of the above-mentioned rivers. Flood controls and navigation do not exist and probably will exist at no time. The precipitation-runoff relations as well as the temperature-glaciernmelting relations (as to the few hours-in-advance-runoff forecast) can be used, however, for the daily arrangements of the storage-exploitation-plan.

The long-term forecasts, usually required in case of multi-seasonal storage operations only, are not discussed because of lack of any long time lasting river state records on the one hand and because of abundant spring discharges being able to refilling the partly emptied reservoirs on the other hand.

As the relatively not thick snowcover uses to melt several times during winter due to in time unpredictable but in frequency often changes of polar and south winds' influence, no spring runoff forecast can be reckoned on base of snow-water storage, except the highest glacial parts of the drainage areas. The lag between fallen precipitation and groundwater feeding of rivers is of by far larger importance, in the permeable subareas before all, and provides a sufficiently long period for the seasonal winter forecast practice.

As the main stress is laid on the winter runoff forecasting, the precipitation-temperature-runoff relations shall be the most effective ones. All storage reservoirs are located in upper river reaches. They will operate during winter in an intervening system of operation, especially they will be coming in the natural course of discharges to modify them in the whole river reach below the storage dam site, in the most suitable direction from the power generating point of view. Just as the precipitation-temperature-runoff relations can be successfully used for the storage feeding forecast, so can they for the river feeding in the reach below the dam site.

Two methods of carrying out of above-mentioned relations are presented, each of them in several modifications. One of the presented methods uses the discharge records only, whilst the second one is based on all measurable meteorological and hydrological values.

Unfortunately, there are no suitable meteorological records from inland and uninhabited highland parts of basins available, especially as to precipitation, the amount and distribution of them varies without any regular precipitation altitude or another relation due to practically negligible island size in comparison to the Atlantic ocean and its air streams.

- a) The guaranteed discharged volume forecast.- This method is presented on Gullfoss, Faxi and Dynjandi records as examples of the mixed type and/or prevailing groundwater feeding type of the Hvítá, Tungufljót and Brúará rivers, the both latter being the tributaries of the former. Making use of the summer and early autumn discharged volumes as indexes of the groundwater state and feeding ability, the relations between these antecedent indexes and the successive winter discharged volumes have been carried out graphically, without any regard to the precipitation and temperature in both the antecedent and consecutive periods at first.

The period considered (from July through April) was divided into two subperiods by inserting the moment of forecast. This moment was moving from September through February. The couples of corresponding values plotted were substituted for the straight or curve lines connecting the lowest values or leaving above all the plotted points.

The random parts of the actual total volumes discharged in the future periods (the differences between the actual volumes and the forecasted guaranteed ones) were worked up in statistical way and satisfactory values of the most expected deviations were got. However, the farther in the winter the forecast moment is moved, the lower deviations are got.

Making use of these graphical relations described, the guaranteed discharged volume through end of April can be estimated on the day whichever chosen. The same goes for the most probably expected mean discharged volume got by adding the random-part-probable-value to the guaranteed one. This random-part-probable-value varies from 37 per cent to 3 per cent according to the forecast-time-moving from September 30 to February 28 (for the mixed type of the earth surface-glacial-groundwater river feeding as at Gullfoss in the upper reach of the Hvítá river).

Significantly lower values have been obtained for the prevailing groundwater-feeding-type as at Faxi station in the Tungufljót river basin, from 2 per cent to 1 per cent respectively.

- b) The precipitation-temperature-runoff relations. -
 If representative temperature, precipitation and discharge record were at hand, the relations between four five or six variables could have been computed numerically or graphically. The available records were used as to both the antecedent and successive periods, and the corresponding results were got as long as the graphical correlating method of deviations had been adopted.

The Gullfoss, Faxi and Dynjandi profiles were chosen as examples again and the above-mentioned relations for two arbitrarily given days of forecasting (namely for the September 30 and December 31) were worked up. As a rule, the runoff in the antecedent period and the precipitation amount in the current one were considered as the most important and influencing variables, the antecedent precipitation as the following one. The degree-days values as the temperature index in both periods were taken into consideration at last.

The accuracy of relations got is quite acceptable with regard to the imperfect original data that have had to be used. For example, the coefficient of variation, computed from resulting random deviations, does not exceed 8 per cent only (as to the Hvítá river at Gullfoss section during the current period from January to April).

For the purpose of forecast, the amounts of precipitation and degree-days in the successive period have to be estimated, however, and then the fault (or inaccuracy) of forecast will become a little high. In the case just quoted, the guaranteed discharged volume forecast may vary in limits of $\pm 13\%$ (90% - reliability considered). The most probable expected mean value may vary in the $\pm 16\%$ -limits, the circumstances being the same.

The details about precipitation distribution, temperature gradient, altitude transformation of degree-day records, more exact method description with many exhibits attached as well as another noteworthy remarks are described and discussed in the report.

As to the establishment of suitable meteorological and hydrological stations as well as to the carrying out procedures, the "Recommendations" should be taken in account.

3 RECOMMENDATIONS

To obtain a sufficiently rich amount of records for the successful forecast and waterbalance relations,

to spare time and money in both the observation and the computation periods,

with regard to the Icelandic river feeding and runoff conditions,

with regard to the needs of the storage reservoirs and power generation,

the following suggestions are submitted as to the field observations and the methods of computation.

3.1 Precipitation and temperature

The more extended network of meteorological (or precipitation, at least) stations should be observed. New stations should be established mainly in the higher inland parts of the Hvítá and Thjorsá river basins, the account of them follows:

drainage area/subarea	km ²	number of stations	
		in original period	in final state
the Hvítá river above Ábóti	1230	1	2
the Hvítá river between Ábóti and Gullfoss	770	1	1
the Tungufljót river	770	1	2
the Laxá-rivers	617	-	1
the Brúará river	707	1	2
Σ the upper Hvítá river system		<u>4</u>	<u>8</u>
the Thjorsá river above Nordlingaalda	2060	1	2
the Thjorsá river between Nordlingaalda and the con- fluence with the Tungnaá river	790	1	1

drainage area/subarea	km ²	minimized recommended number of stations	
		in original period	in final state
the Kaldakvísl river above Thorisóss	1120	1	1
the Thórisvatn lake area and the upper Tungnaá river	1950	1	2
Σ the upper Thjórsá and Tungnaá rivers area		<u>4</u>	<u>6</u>

The minimum of eight precipitation stations should have been in operation during a five years' period at least, before the more precise seasonal forecast and water balance-making will start. Making use of the computing machine programme prepared in advance, all characteristics needed shall be got quite quickly and reliably.

Temperature, amount (and kind) of precipitation should be recorded on stations mentioned above, wind direction and force records in addition, if possible.

If only precipitation collectors (totalizers) would be established, observations should be made as often as possible, in shorter than monthly periods on any account.

Occasional and in area limited snow courses are of little if any representative use. That's why they are not recommended to be carried out in a larger extent.

Additional meteorological and hydrological stations located at operating water power plants and observed by staff of them go without saying. They will be able to do a lot of useful work (with the other stations together) especially for the daily arrangements of the storage-exploitation-plan.

3.2 River discharges

The number and location of water gauge stations being in operation at present time - is quite suitable to the seasonal forecast and water balance computations as required and therefore, it is not necessary to consider and discuss any essential corrections of the present stage recorders' number or location.

3.3 Groundwater stage

To obtain additional groundwater storage data, the groundwater level amplitude might be observed at a few number of places in the most permeable areas (that is e.g. the Thórisvatn drainage area) approximatively in the same way as the groundwater level research observations at Thingvallavatn, which are carried out at present time by the staff of the State Electricity Authority.

These observations should be carried out only to get additional values for the local problems solutions. The past discharges records seem to be the main and best index of groundwater level state during the winter season in large areas.

3.4 Methods of computations

To obtain the basic elaboration of regularly recorded or observed variables, electronic or transistored computers should be used.

To be looking for suitable relations between variables the number of which does not exceed six or seven, the graphical methods will be the most suitable and usable ones still for a long time. This preference-making does not exclude, however, the use of numerical methods as well as the use of available ready-made computer's programmes, especially in the case of the correlation-characteristics-computations

and in similar cases. It is to be said at last but not at least that the usually presented preciseness of numerical solutions is of little use only in this case, with regard to the rough estimated or rounded off values that are entering the numerical procedures.

The computer programming of the whole seasonal forecasting procedure might not be taken under consideration before some successful experience with graphical solutions will have been got.

4 ACCOUNT ABOUT ICELANDIC RIVER RUNOFF CONDITIONS AND RECORDS AVAILABLE, ESP. AS TO THAT OF THE HVÍTÁ AND THJÓRSÁ RIVERS

4.1 General hydrological description

The average runoff for Iceland as a whole is approximately 55 litres per second per square kilometre. The highest runoff occurs near the south and west coast in mountainous regions; the lowest one in inland areas of the North and East Iceland. Most of the drainage basins are relatively small. The largest is that of the Jökulsá á Fjöllum river in the north (7950 square kilometres), the following is the Thjórsá river basin (7530 square kilometres) and the Hvítá river basin (6100 square kilometres), both latter are located in the south. In relation to the whole area of Iceland, it is 7,7, then 7,4 and 5,9 per cent, respectively.

The relatively high runoff per unit area in the south of the country creates rivers of appreciable magnitude. From this point of view, the Thjórsá and Hvítá rivers are the biggest ones, with an average discharge of about 390-395 m³/s in each of them. (The Jökulsá á Fjöllum river has a 190 m³/s discharge only because of location in the north).

From the standpoint of power production, the Hvítá and Thjórsá rivers are the most important rivers of the country. The total technically harnessable water power in Iceland was estimated at 35000 GWh a year (under normal hydrological conditions), from which the greatest potential belongs to the Thjórsá river basin (30 per cent) and to the Hvítá river basin (13 per cent).

As to average runoff in both Thjórsá and Hvítá catchment areas, its size varies from a 120-140 l/s/km² value in the mountainous part covered by glaciers over to a 40 l/s/km² value in the plateau of the middle part through 50 l/s/km² near the coast.

As to temperature and precipitation in these two basins mentioned above, we are not able to give a general description for lack of any regular long time lasting records in the uninhabited inland sections. From a 30 years' period of observation on the meteorological stations Eyrarbakki (located at the coast near to the Hvítá river estuary) and Haell (located in a 45 km distance from sea in a 130 m elevation near the watershed between the basins of the Hvítá and Thjórsá rivers) a brief account is of use and may be quoted here:

	mean temperature (1931-60) °C						
	Jan.	March	May	July	Sept.	Nov.	year
Eyrarbakki	-0,7	0,9	6,8	11,3	8,2	2,0	4,6
Haell	-1,7	0,3	6,6	11,7	7,8	1,2	4,2

	mean amount of precipitation (1931-60) in mm						
	Jan.	March	May	July	Sept.	Nov.	year
Eyrarbakki	138	109	72	79	127	137	1342
Haell	92	82	59	76	113	103	1064

The mean daily range of temperature (near the coast) is negligible during the winter period but ca 2°C in summer. Maximum temperature on the warmest days may exceed 20°C, minimum on the coldest days is usually below -20°C in the inland and on the northern coast of the country.

The amount of precipitation varies from place to place and depends before all on the wind direction, location of the place, its exposure and unfortunately at last on the elevation above the sea level. Spring and early summer is the driest part of the year with some 15-20 days per month without rain in these two basins.

The hydrology of the Icelandic rivers is strongly influenced by the geological conditions of the catchment areas. The upper parts of the Hvítá and Thjórsá rivers basins are mainly resting upon a sequence of basalt flows and interbedded sediments. Topographically, the valleys of both rivers are streamlined in the SW direction, ^{modified} by glacial erosion and deposition. The lower courses of the Thjórsá, the

Tungnaá (tributary of the previous one) and the Hvítá rivers are in most places located along the borders of the Thjórsá lavas.

The most part of these two basins discussed above is undeveloped and uninhabited. There are scattered villages and farms at the lower altitudes only. The earth surface is generally barren, without any trees, except the coastal section covered with grass.

Icelandic rivers are usually divided into two basic types: (1) glacial streams and (2) clearwater or non-glacial streams. As a matter of fact, a pure glacial stream exists only at the snout of a glacier. After leaving the glacier, it receives additional water as surface and groundwater runoff. These streams are called glacial streams (and marked "J" from "jökull=glacier") usually throughout their whole length, mainly because of the milky to brownish colour of water.

The clearwater streams ("bergvatnsá=rock water river") are divided into two groups again: (1) "dragá" or direct runoff streams and (2) "lindá" or groundwater fed rivers. These names are due to the low or high permeability of the earth layers. Dragá streams ("D") are associated with impermeable basins. Their discharge depends very much upon the precipitation and the water temperature varies in connection with the air temperature alterations. The great floods of the dragá rivers carry great volume of sediments, but at other times the water is clear.

Lindá streams ("L") are associated with permeable basins. Their water is clear, has nearly constant temperature and discharge all the year round.

However many Icelandic streams are the mixtures of these three types. Their hydrogram may be influenced in addition by the transformation effect of the lakes, if any. Then we obtain the "J+L+D+S river": it is a glacial stream with an important influence of the groundwater ("L"). The dragá effect ("D") and the lake influence (due to its storage) S are of lower importance only.

To have a better general view, several maps, figures and tables are attached in the supplement of this report. Their content, however, will be discussed particularly in next chapters.

4.2 The HVÍTÁ river system

Several small rivers and brooks run into the lake HVÍTÁRVATN, located at the southeast border of the LANGJÖKULL ice cap, the SVARTÁ river and the FÚLAKVÍSL being the biggest of them.

The Hvítárvatn lake is believed to be the origin of the HVÍTÁ (= White River). Its volume of water can be estimated next to 800 mill. m³. This volume would be filled due to an average discharge of 77 m³/s - in a period of 120 days.

The main tributaries of the Hvítá river from the left are the JÖKULFALL, the SANDÁ and the conjugate STÓRA- and LITLA-LAXÁ rivers. The Jökulfall river is coming from the west part of the HOF SJÖKULL ice cap. The other tributaries from the left are completely dragá rivers almost.

From the right, there are the TUNGUFLJÓT, the BRÚARÁ and the SOG rivers as the main tributaries of the Hvítá river. The flow of the Tungufljót river is mainly a "L"-flow, and the same in a greater extent goes for the Brúará river.

The largest tributary of the Hvítá river is the Sog river, a lindá stream originating in the lake THINGVALLAVATN, the largest lake of the country. Its waterstorage is about 2800 mill. m³, which could be filled in a 300-days' period due to an average discharge of the Sog river 110 m³/s.

The last part of the Hvítá river system, the 25 km long reach below the confluence of the SOG and HVÍTÁ rivers is named as the ÖLFUSÁ river. In the following, however, the Hvítá-Ölfusá basin will be referred to as the Hvítá river basin only.

Numerous waterfalls and rapids are on the main stream and its tributaries. Below the lake Hvítárvatn, the riverbed drops 155 m over a distance of 18 km (8,6 o/oo), in the Gullfoss' reach there are 100 metres over 8 km (12,5 o/oo), in the lower part at Selfoss 45 m over a 28 km (1,6 o/oo) distance. The highest waterfall in the Hvítá river is GULLFOSS, 30 m approximatively.

The waterfalls of the Sog river (LJÓSAFOSS, ÍRAFOSS and KISTUFOSS) are almost completely used for the energy production in the Sog river hydroelectric power plants system.

4.3 The THJÓRSÁ river system

According to the division used by Olaf Devik in his UN Special Fund final report about the ice conditions in this area, we divide the Thjórsá river system into three main sections as follows:

- (1) the UPPER THJÓRSÁ river basin, above the confluence of the Thjórsá and Tungnaá rivers (with the topographical catchment area of 2850 square kilometres, of which as large a part as 512 km² is covered by glaciers)
- (2) the TUNGNAÁ river basin, the size of the drainage area a little larger than the previous one (3470 square kilometres, where the glacial part of 688 km² is included)
- (3) the LOWER THJORSÁ river basin, below the confluence of the upper Thjórsá and Tungnaá rivers (with its own drainage area of 1210 square kilometres in the reach between the confluence mentioned above and the ocean).

- (1) The THJORSÁ river is coming from the sources on the high plateau located between the HOF SJÖKULL and VATNAJÖKULL ice caps. Its flow is substantially a dragá stream (direct runoff) with a considerable deal of glacial meltwater.

The BERGVATNSKVÍSL, FJORDUNGSKVÍSL and SVARTÁ tributaries are coming from the left and the KISÁ and DALSA rivers are contributing from the right.

In the 10 km long THJÓRSÁ GORGE we find a fall of 160 m concentrated into two great waterfalls and associated rapids. HVANNGILJAFOSS (14 m over a 600 m reach), DYNKUR (63 m over a 800 m course) and GLJÚFURLEITARFOSS (29 m) are the waterfalls of considerable importance.

- (2) The TUNGNAÁ river comes from the west part of the VATNA-JÖKULL ice cap. Its riverbed slope is considerably irregular and varies to a great extent from place to place. The most important waterfalls are BJALLAR (18 m), TUNGNAÁR-KRÓKUR (10 m), SIGÖLDUFOSS (12 m) and HRAUNEYJAFOSS (96 m together with associated rapids)

An important tributary from the right is the KALDAKVÍSL river with its origin also in Vatnajökull ice cap. A short river Thorisós drainages the Thorisvatn lake into the Kaldakvísl river. This lake presents a remarkable storage of water (its value of 2800 mill. m³ is practically the same as that of the Thingvallavatn lake). It is fed by undergroundwaters totaly and the outflow is realized in the small Thorisós river (its average discharge is believed to be about 10 m³/s) on the one hand and in a lot of subsurface leakages into the lower parts of the basin on the other one.

- (3) The lower THJORSÁ, below the confluence of the upper Thjórsá and Tungnaá rivers, is a broad and powerful river. The TRÖLLKONUHLAUP waterfall (total fall of a series of falls and rapids is nearly 90 m over a section of 7 km lenght) presents the most concentrated energy potential of both Hvítá and Thjórsá rivers basins. The SKARD RAPIDS (15 m), BUDAFOSS (7 m) and finally the URRIDAFOSS (35 m over a gorge section of 4 km length) are the other important waterfalls.

The estuary is influenced by ocean tides within a distance of about 10 km.

4.4 Meteorological and hydrological data relevant to the water balance and runoff forecasting

The climate in Iceland is a rainy island climate, the summers are rather cool and the winters warm. The depression zones which originate from the east coast of America move north across the Atlantic (nearly in the same direction as the Gulf Stream) and north over to Iceland and bring great volumes of humid and relatively warm air over the country. But the Polar Sea and Greenland, the sources of cold air are not far away. Therefore the weather depends on whether the warm southern or the cool northern winds dominate.

Meteorological stations with continuous series of observations in fact were established only in the inhabited parts of the country. Three of them are found within the Hvítá and Thjórsá river basins, viz. HALL, JADAR and THINGVELLIR (with the start of observations in the years 1932, 1956 and 1934, respectively). They are located at lower altitudes, 130, 160 and 105 m resp.

Several other precipitation stations are disposed in the country as shown in the map.

Snow measurements on the glaciers and 7 integrating collectors (totalizers) of precipitation, placed in the uninhabited southern parts of the highland, give supplementary values of precipitation.

In the winter season 1965/66, a new meteorological station HVERAVELLIR was established in the region between the Langjökull and Hofsjökull glaciers in an altitude of above 600 m.

A fraction of precipitation falls as snow from September to May, its percentage is much influenced by the local topography and climate and therefore it is varying to a great extent during the winter. We can safely be expecting the rainfall to occur at any month and at any place of the country all the year round. Most of the winter precipitation above the 500 m elevation falls as snow, of course.

The fluctuations of precipitation cause variations in the river discharges. Floods may occur at any time and their intensity may be influenced by melting of snow cover through rainfall and air temperature.

As to hydrological records there are at present 22 gauging stations in our two basins discussed, many of them are equipped with level recorders. In order from origin to mouth of the main streamflow, the main recorders are as follows:

river (tributary)	water gauge No	location	drainage area km ²	in operation from the year
HVÍTÁ	57	Hvítárvatn	843	1959
	101	Ábóti	1230	1959
	87	Gullfoss	2000	1949
	41	Ida	3540	1948
	64	Selfoss	5760	1950
Tungufljót	68	Faxi	720	1951
Brúará	43	Dynjandi	670	1948
Sog	2	Ljósifoss	1050	1939
THJORSÁ	100	Nordlingaalda	2060	1959
	97	Tröllkonuhlaup	6320	1959
	30	Urridafoss	7200	1947
Kaldakvísl	95	Saudafell	1120	1959
Thórisós	94	Vad	330	1958
Tungnaá	96	Vatnaöldur	1350	1958
	98	Hald	3400	1959

5 RIVER FORECASTING

5.1 General consideration

The energy resources of Iceland are the hydro power potential on one hand and the geothermal energy potential on the other. The harnessable value of the former was estimated at 35000 GWh a year (as it was mentioned above), the value of the latter is divided into the recurrent form (natural dissipation of heat - 1 mill. Kcal per second) and into the non-recurrent form (heat content of the bedrock in the thermal areas - 10^9 Kcal) of which between one and ten per cent is recoverable. Therefore, the river energy potential is of great importance in Iceland.

Water supply for domestic and industrial purposes has never been a serious problem in the country (except in a few special cases) and probably will not be in the future years because of abundant precipitation. Hydro-electric power generation is by far the most important use of the water resources. River navigation or floating of timber does not exist. Almost negligible quantities of water are used for irrigation (a few weeks of the year). Flood control is of small economic importance: flood damages practically do not exist in the uninhabited and uncultivated areas nearby the rivers. Fresh-water fishery is of some importance. It is the only economic activity which may offer any noteworthy competition with power generation for use of the water in the future.

The UN Special Fund Project in Iceland for development of the Hvítá and Thjórsá river basins provides that a range of water power plants and supplementary constructions will be put up. There are four or five large storage reservoirs in this number of constructions. It is supposed that the volume of these reservoirs will be used during the period of lower discharges in the rivers to increase the hydro-power generation. As the period of low discharges and that of the necessity of electricity are the simultaneous ones, a good runoff forecasting can make a lot of useful work at this time.

As a rule, the river forecastings may be divided into three main group according to the length of the period which is to be covered up, viz.

- i) short-term forecastings (from the shortest period up to few days)
- ii) middle-term or seasonal forecastings (from a few weeks' period through several months)
- iii) long-term forecastings (for one year's and longer periods)

The first type, namely the short-term forecast (of discharges, hydrographs, stages and so on) is of use for flood control purposes, in large and long rivers, for navigation purposes as well as for the daily arrangements of the storage-exploitation-plan. As it was discussed above, the length of Icelandic rivers does not exceed the range of 200 km only. This kind of forecastings is of disputable use for the relatively short Hvítá and Thjórsá rivers, equipped with large storage reservoirs on the main streams and its tributaries. (Floods will occur suddenly, practically simultaneously with heavy rainfalls. The storage reservoirs - and mainly the spillways of their dams - have to be prepared at any time all the year round to accept and smooth the sharp peaks of floods.) The precipitation-runoff relations as well as the temperature-glaciermelting relations can be used however, for the daily arrangements of the storage-exploitation-plan, especially as to the few-hours-in-advance-runoff forecast from low permeable areas without any remarkable natural or artificial storage reservoirs.

The seasonal forecasting of river discharges or discharged volumes of water is of great importance for storage-reservoirs and water-power-plants-system operation. It will be discussed in the following chapters.

The long-term forecasting is of some use in cases of multi-seasonal storage regulation systems.

5.11 River discharges variability

The lindá rivers have their discharges nearly constant all the year round. The dragá rivers' discharges depend only on the seasonal distribution of precipitation. There are no expressive seasons of precipitation in Iceland and a heavy rainfall may occur at any season of a year. Therefore the melting of glaciers only as well as the snowmelting (in lower extent) is influenced by changes of seasons. As the Hvítá and Thjórsá rivers have both their origin in the glacial areas, a general decrease of their discharges can be observed during the winter season (from October through April). This decrease however is conducted by occasional increases (due to greater amounts of precipitation or positive temperature). A good estimation of the discharged volume for each month's or two month's part of this winterperiod in advance may influence substantially the plotting of the dispatching diagrams (of the proposed drawdown of the storage).

5.12 Storage reservoirs

A The Hvítá river basin

It is proposed to rise the natural water level of the Hvítárvatn lake for about 19 m up to the altitude of 440 m (due to a dam construction) and then to release (during the period of lower discharges) the 20 m thick waterlayer, which equals to a 1130 mill. m³ volume of harnessable water.

The drainage area of this storage reservoir (1230 km²) is approximatively a 1/5-part of the total Hvítá river system catchment area.

B The Thjórsá river basin

Three of the large storages are in basic consideration: The Nordlingaalda reservoir (at the cross-section of the same name in the upper Thjórsá river reach) has the 2070 mill. m³ large volume between the usable waterlevel elevations 593 and 557 m.

The water surface of the Thorisvatn lake will be risen from a natural elevation of 571 m to an artificial one of 576 m, and than a 31 m thick layer (1950 mill. m³) will be used to supply the system of water power plants during the period of low natural discharges.

The Snjóaldá reservoir (Upper Tungnaá river) is supposed to have a 940 mill. m³ large volume of usable regulating water below the highest water level elevation 620 m.

In addition, the Langisjór storage (340 mill. m³ approximately) can be taken into consideration provided that a tunnel would be built connecting the Langisjór lake (laying out of the Thjórsá river basin) with the Thjórsá river-water-power-plants-system.

The total regulating storage (the impounded water) can be estimated at a 1130 mill. m³ value in the Hvítá river basin and at a 5300 mill. m³ value in the Thjórsá river basin.

5.13 Seasonal water-supply forecasts

Long-range water-supply forecasting is generally limited to those areas where the lag between winter snowfall and spring runoff provides an opportunity for advance recommendations on one hand or/and where the lag between fallen precipitation and groundwater feeding of river provides a sufficiently long period on the other hand.

As to me, I estimate the former kind of forecasting based either on measurements of snow water equivalent or on precipitation records is of a lower use in Icelandic conditions. By far the most part of the winter precipitation fallen as snow is melting several times during the winter because of unpredictable changes of cold and warm air masses above the country. Only the glacial part of drainage areas will keep a remarkable amount of water in the snow-cover for a long time.

The latter kind of forecasting based on relations between streamflow and ground-water flow and storage has a predominant importance in the lindá river drainage areas and a noteworthy importance in other mixed types of river basins.

Unfortunately, an insufficient amount of historical records from the inland part of the island is available, nowadays. We are able to show the methods of usable and required forecasting, using only the imperfect data which are at our disposal today. Therefore the deviations of the estimated-forecasted values from the actual ones will be a little higher than the deviations obtained on the basis of sufficiently perfect original data would be.

5.14 Runoff forecasting (except spring runoff)

This chapter is devoted to short description of the original records and methods which we are in need of to elaborate a suitable forecasting of discharged watervolumes in the period of prevailing groundwater feeding.

We are able to present the discharged volume of water (through a given river cross-section) in a larger time period like the following equation:

$$V_{\Delta t} = W_0 + V_G + V_S \quad (1)$$

where $V_{\Delta t}$ - the discharged volume in the Δt -period (from $t = 0$ through $t = \Delta t$)
 W_0 - watervolume of riverbed (and lakes, if any) at $t = 0$
 V_G - volume of groundwater feeding, during the Δt -period
 V_S - volume of surface runoff (rain or snowmelting) in the Δt -period.

Nowadays, however, the W_0 -value is the perfect one only, both the V_G and V_S -values can be computed as approximative estimations.

To cut the long matter short, we often use approximative relations:

$$V_{\Delta t} = f(y) + f(x) \quad (2)$$

where $f(y)$ - function of river- and groundwater-state characteristics (in the period just before the moment $t = 0$)

$f(x)$ - function of (effective) precipitation characteristics (in the period Δt)

To obtain plain and exact information about the theory and practice-making of forecasts, we recommend the reader should be acquainted with some of remarkable books (mentioned in the References as [1], [2], [4]) in English or Russian.

As to forecasting one month (or less) in advance, the last component of the (b)-equation uses to be small and negligible, as a rule. In such a case, the

$$V_t = f(y) \quad (3)$$

equation can be used successfully as a quite perfect estimation. The same goes for longer periods when the precipitation influence is of less importance.

5.15 Spring runoff forecasting

Short-term forecasting of the riverhydrographs during the snow-melting period is of disputable use in Icelandic conditions as was mentioned above. The middle-term (or seasonal) forecastings of the spring discharged watervolumes are of little importance only (it is practically guaranteed in most years that the storage reservoirs will be filled up during spring, because of high value of specific runoff in the Hvítá and Thjórsá river catchment area), but they are not negligible.

Theoretical relations (in connection with spring runoff forecasting) are dependent on a lot of variables [1] like (e.g.) on

- the snowmelting intensity
- the percentage of the snowcovered part of the catchment area
- the coefficient characterizing the relation between the snowmelting intensity and the snowmelting runoff
- the amount of liquid precipitation during the period of forecasting

- the losses of snowmelting water and liquid precipitation
- the changes in the earthsurface waterstorages during the period under consideration

The spring discharged volumes forecasting is based on the knowledge of the both groundwater and surface components and (as to the latter one) on the estimation of the watercontent in the snow and ice cover as well as in the liquid precipitation (during the thaw period) and on a range of other estimations of the earthsurface state. It is practically impossible to establish a lot of observing stations in an uninhabited region (most parts of it are difficult to access - by helicopter only). As the precipitation kinds and conditions as well as the earth-surface morphology vary to a great extent it would be necessary to establish a relatively great number of the observing points (in relation to the size of the drainage area) and this way would not be the economical one.

As to the methods of computations, the same ones might be used as in the matter with the winterrunoff forecasts described in next chapters.

5.16 River forecasting in upper mountainous parts of basin

The main characteristic of such a drainage area seems to be the vertical distribution of precipitation, air temperature and runoff. Nowadays, a successful forecast of discharged volume during one month's or longer periods can be carried out. Plotting of empirical relations between the runoff and several influencing factors can be reckoned as the basic method of the river forecasting in mountainous catchment areas. Lack of sufficiently precise and extensive observation records used to be the main trouble and difficulty of the research work. Several other regular relations (in most basins) can be considered as a compensation for this shortage, e.g.

- the relation between altitude and several meteorological values and so on.

The basic relations, we are in need of them for a tolerable forecast elaboration, are as follows:

- hypsometric curve of the drainage area
- precipitation/altitude distribution
- temperature/altitude distribution

Unfortunately, there is no regular precipitation/altitude relation in the inland part of Iceland. To better the preciseness of forecasted values a relatively high number of precipitation stations had to be established in the upper parts of river basins.

5.2 Winter runoff forecasts based on hydrological records only

In case of lack of meteorological records, a relatively simple method of forecasting could be used provided that the groundwater feeding is of remarkable influence. Three of many observed cross-sections of the Hvítá and Thjórsá rivers were chosen to demonstrate this possibility:

- 1) Gullfoss-profile on the Hvítá river, located just below the waterfall of the same name and equipped with a stage recorder. Its 2000 km² large catchment area wears a D+J+S+L characteristic, which is not so suitable as it should be required from a scholastic point of view
- 2) Faxi-profile on the Tungufljót river (a tributary of the Hvítá river), including by far the most part of the total Tungufljót river drainage area 720 square kilometres from a total sum of 770 square kilometres). The L+J characteristic is used to general description of the basin.
- 3) Dynjandi-profile on the Brúará river (another tributary of the Hvítá river), finishing the 670 km² large drainage area of the L+S characteristic.

5.21 GULLFOSS (HVÍTA)

Monthly sums of discharged volumes were available from the eight years' period (beginning in the wateryear 1950/51, then on sept. 1, 1950). Progressive sums of monthly discharged volumes were computed for each wateryear in both directions, forward (with starting point on July 1) and backward (beginning on April 30), respectively. (Tables No 3 and 4). Then, several relations were plotted between the runoff in the antecedent period and the one in the immediately successive period. The terms "antecedent" and "immediately successive" are written from a forecasting point of view: the whole winter period (September to April) is divided by the moment of forecasting into two parts, the antecedent period and the successive (future) one.

Making use of these relations, it is possible to forecast the minimum water supplies for any given period of the winter: a straight line is drawn below all plotted points (see Fig. 8). The groundwater feeding and the guaranteed minimum of surface runoff is included into this kind of estimation. Any assumptions as to future higher precipitation may be introduced in addition to provide an indication of the possible range of runoff to be expected.

There are six moments of forecast on the Fig. 8, each of them on the last day of month given, as a rule. To obtain another forecast on another interjacent date we may interject an additional line simply into the drawn bunch of basic straight lines.

The random part (depending on unpredictable higher amounts of precipitation) of actual total volume discharged in the winter period (October to April) was computed (see table 5) and plotted on Fig. 9. Making use of the probability theory (discussed in many professional books and papers), we are able to estimate the additional component of forecasted guaranteed minimum, which may occur with a 50 per cent - probability (it is the - so called - most expected probable value) or with another size of probability elected according to the probability-theory-laws and theorems. The number of

points plotted (Fig. 9) being at our disposal to-day is too low to permit the reliable demonstration of computations as to probability. Then the graphical method is used only to gain time and to estimate the course of the 50 and/or 90 per cent-probability-curves. These curves, however, should be computed at once after certain time when a sufficient amount of records would be available.

Example 1: A forecast of future guaranteed discharged volume is to be carried out

- in the Hvítá river at Gullfoss-section
- on October 31, 1957
- for the whole winter period (from Oct 1, 1957 till April 30, 1958)

and based on following known values:

- discharged volume 1245 mill. m³ G1 (July to Oct, incl.)
- discharged volume 303 mill. m³ (in Oct only)

then 1) compute the guaranteed forecast for the successive period (according to "x 1245" and the "Oct.31" - line) (Fig. 8) 1100 G1.

- ii) compute the same forecast as above - for earlier moments of forecast, e.g. for Sept. 30. You will obtain the 1140 G1-value, according to "x = 942) and "Sept. 30"-line on Fig. 8

- iii) Compare the two (or more) computed values:
1140 G1 (got on Sept. 30) and 1100+303
1403 G1 (got on Oct. 31).

Both these values (1140 and 1403, respect.) are valid for the same period (Oct. to April, incl.) and both are guaranteed, too. Neither the first nor the second value shall be lower than the actual one. Therefore, the 1403-value may be accepted as the most suitable result of forecast.

Example 2: The same forecast (as in the example 1) is to be computed, except the moment of forecast only:
- on February 28, 1958

It is taken for granted that several forecasts have been made in the past period (according to example 1):

1140 G1 on Sept. 30
1403 G1 on Oct. 31

.

.

760+847 1607 G1 on Dec. 31

and so on.

Then (according to "x = 2129 G1 - discharged volume from July 1 through Febr. 28" and to the "Febr. 28-line" on Fig. 8) we shall get 370 G1

as the forecast for the rest of the winter period (March to April)

and 1187 G1

as the actual discharged volume (Oct. to Febr.) in addition

and finally 1557 G1

as the value as required.

Comparing this value with other estimations got earlier (1557 with 1607, 1403, 1140), we have to believe the highest estimation (1607, got in Dec. 31) is the most suitable value of guaranteed discharged volume in the winter (Oct. to April) of the water year 1957/58.

Example 3: A forecast of the most probably expected mean value of discharged volume is required as to

- the Hvítá river at Gullfoss-section
- the October 31, 1957
- the winter period (Oct. 1 to April 30)

There are discharge records available, only. At first, we are getting the 1403 G1-value as discussed in the example 1.

Making use of the Fig. 9 as to "Oct. 31" on the x-scale and "50%" probability curve, we will find the "0,25/or "25%"-value on the y-scale. Using the equation

$$1403 + 0,25 \cdot V = V$$

we'll get

$$V = \frac{1}{1-0,25} \cdot 1403 = 1870 \text{ Gl}$$

as the best impartial estimation of the discharged volume.

---o0o0o--o0o0o---

After additional six years' records had been obtained (from Gullfoss cross-section, wateryears 1958/59 till 1963/64), the developed method was tested on base of these new observations (see table 6). A satisfactory result was obtained:

- a) all deviations above the forecasted minimum were the positive ones
- b) all deviations out of the most expected value were in reasonable limits and almost symmetrically distributed

Quite a good correlation between monthly and seasonal values of runoff can be taken into consideration, therefore. That is of great importance for planning of storage-waterhousehold during winter.

To have a look on limits of correlation, a correlation between two successive yearly discharged volumes was tried to carry out using the Gullfoss' records. The simple graphical method was adopted to compute the correlation coefficient from the two regression lines (Fig. 10) No suitable value was obtained. - Standard deviation S of a coefficient of correlation $r_0 = 0$ computed from "n" couples of numbers, uses to be expressed as

$$S_{r_0} = \frac{1}{\sqrt{n}}$$

In connection with probability theorems (Gauss' normal distribution law), it can be expected that two thirds of all computable correlation coefficients of no importance will be included in

$$- S_{r_0} < (r_0 = 0) < + S_{r_0}$$

Then - in our case -, $S_{r_0} = (1 : \sqrt{13}) \doteq 0,28$

$$- 0,28 < (r_0 = 0) < + 0,28$$

Our computed (graphically estimated) value, viz. $r = 0,15$, is included in the limits shown above. Therefore, no important linear correlation between two successive yearly discharged volumes exists.

5.22 FAXI (TUNGUFLJÓT)

Another system of recorded values (than in the case of Gullfoss cross-section) was available. Making use of progressive weekly sums of discharged volume, we computed the relations between the "antecedent" and "successive" subperiods of winter season (Fig. 11) (Table 7)

The basic working method is theoretically the same as in the antecedent Gullfoss-case, therefore, we shall not spend time to describe it and will discuss the results, immediately.

The Tungufljót river runoff is by far more influenced by groundwater feeding than the Hvítá river runoff at Gullfoss. Therefore, the guaranteed discharged volume forecast covers a remarkable part of the total discharged volume. The random (unpredictable) part expressed in per cents (Fig. 12) is of little size at the end of September already and diminishes at later dates. A 1- or 2-per cent value is to be added only to obtain the most expected volume from the guaranteed one.

5.23 DYNJANDI (BRÚARÁ)

A similar kind and amount of available records were considered as in the matter about Gullfoss' guaranteed volume forecast. Using the first nine years' period of observation, progressive monthly sums have been computed forward and backward, from which several relations between the antecedent and successive values were carried out (tables No 10 and 11 and Fig. 13) together with the random part - occurrence - probability curves (Fig. 14, Table 12)

A test of computed relations, based on records from successive 6-years of observation, can be seen on table 13. The suggested forecast method seems to be quite suitable.

5.24 Conclusion

If a sufficient large range of streamflow observations were at our disposal, similar relations could be carried out as to each water gauge section and its catchment subarea.

This method of forecasting is possible and suitable in Icelandic conditions. The knowledge of weather conditions, namely that of precipitation fallen and air temperature can improve the preciseness of discharged volume forecast. This matter will be discussed in next chapters.

Using the simple forecast method described above, we can put several subarea forecasts together to obtain a new forecast valid for one of the lower reaches of the river. Such kind of relations is shown in Example 4 for the Hvítá river reach below the confluence of the Hvítá, Tungufljót and Brúará rivers (if such a reach would exist, however). The 3000 G1-value is granted on Sept. 30, 1957 for the whole winter in advance. This value can be improved (it means: it will usually be corrected to a little higher value) during the winter.

Example 4:

Forecast of guaranteed (and the most probable expected) discharged volume below confluence of the Hvítá, Tungufljót and Brúará rivers (winter 1957/58, moment of forecast: Sept. 30)

river (section)	discharged volume July to Sept. in G1	forecasted volume Oct. to April, in G1			actual discharged volume Oct. to April in G1
		mini mum	$\Delta Q\%$ (50%-pro- bability)	the most expected value	
Hvítá (Gullfoss)	942	1140	37	1810	1637
Tungufljót	394	780	2	795	781
Brúará	423	<u>1080</u>	10	<u>1200</u>	<u>1197</u>
		3000		3805	3615

5.3 Winter runoff forecast using both the hydrological and meteorological records.

The most important and successful result of forecast research work is to fish out the most suitable and reliable relations between the determining variables or its characteristics. In Icelandic conditions, this reliable forecast schedule should be taken under consideration:

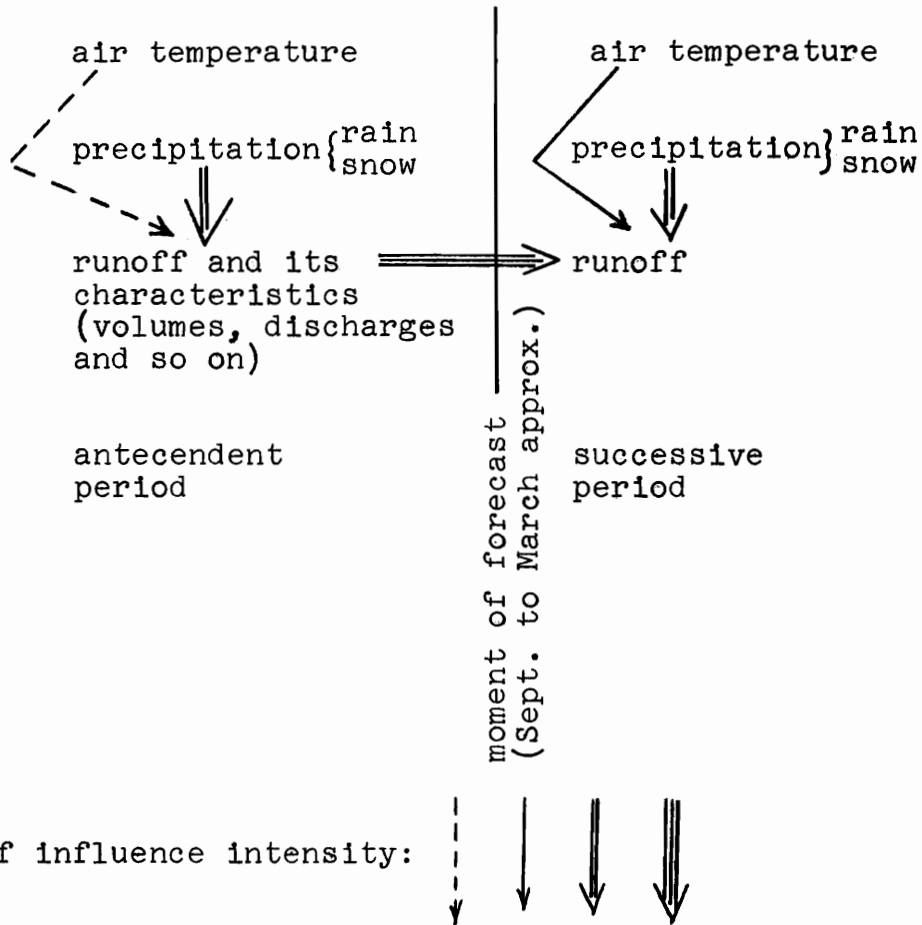

To get several usable meteorological characteristics from past records of some stations, a computing program was suggested using the IBM electronic computer. The results got are as follows:

Meteorological stations HÆLL (64°04'N; 20°15'W; El. 130 m)
 THINGVELLIR (64°15'N; 21°07'W; El. 105 m)
 EYRARBAKKI (63°52'N; 21°09'W; El. 5 m)

Period 1949 to 1964, if records available

- 1) daily mean temperature
- 2) weekly sums of degree-day value above 0°C
- 3) the same as 2), above 2°C
- 4) the same as 2), above 4°C
- 5) the same as 2), above 6°C
- 6) progressive sums of values from line 2)
- 7) 3)
- 8) 4)
- 9) 5)
- 10) daily amount of precipitation (total)
- 11) the same of rain only (50 per cent of mixed precipitation
in addition)
- 12) the same of snow (50 per cent of mixed precipitation
in addition)
- 13) weekly sums of values 10)
- 14) 11)
- 15) 12)
- 16) progressive sums of weekly values from line 13)
- 17) 14)
- 18) 15)

5.31 Temperature relations

It seems that Haell-records are the most complete ones. Making use of them and of several sporadic temperature measurements in the mountainous inland part of country, got during a few summer seasons only, - we estimated the temperature gradient in range from 0,4°C/100 m to 0,8°C/100 m, the more precise estimation of that depends upon current month (see table 14).

The degree-days values, which by far most influence the snow-melting in higher altitudes, can be computed from Haell station records using the temperature gradient estimation and the transforming coefficient curves (Fig. 15). These curves were carried out on base of Haell-computations and tested with results obtained from Thingvellir-computation (table 15).

The gradient estimations as well as the transformation coefficient curves are the preliminary ones, however, and should be computed at once after a higher amount of suitable observation records will be available.

Quite suitable relations between degree-day values at Haell and Thingvellir can be shown in Fig. 16. That's just why we often use only the Haell-degree-day values as the index of temperature conditions in quite large areas.

5.32 Precipitation relations

Because of lack of any regular and repeated snow measurements - we tried to find any relations between the total amount of precipitation on one hand and the altitude on the other. Unfortunately, no such a relation exists in Iceland due to the predominant influence of sea winds directions and important part of natural hindrances and their shape.

The Haell- and Thingvellir-meteorological stations are both located at almost the same altitude, but remarkable differences in amount of precipitation fallen can be shown in single years, without regard on the length of the period being under consideration (Fig. 17). Most of the plotted points are suitably distributed around the elected curve, but quite a number of them has an independent distribution. Consequently we have to expect higher deviations from forecast equations and graphs (which are to be carried out). And at last but not at least, this reality asks for a relatively high number of new meteorological /or precipitation stations to be established in the future to better preciseness of the river forecastings.

5.33 Runoff forecast relations

The runoff forecast relations at Gullfoss' river section will be discussed at first, eventhough the river characteristic at this profile is not so suitable as might be supposed.

That's just why the method will be described on this case to throw light upon the use-making of relations in such natural conditions (and not in that of artificial construction or rare occurrence).

A graphical method is adopted the relations between more than three variables to be computed. Several advantages of this kind of work can be considered, as for example

- a) results obtained attract more attention than the results expressed in mathematical equations
- b) drawing of several relations is simpler than the primarily numerical computation by hand and gains time in addition
- c) resulting curves are suitable, as a rule, to all purposes required
- d) mathematical equations of all relations can be got using the well-known methods everywhere, if necessary
- e) preciseness of the results graphically obtained is practically the same as that of the numerical procedure with regard to rough values accepted for computations, particularly.

There are several methods for graphical correlation of four or more variables. They are completely described in many publications. The coaxial correlation method and the method of deviations are the most important and extensively used ones. The latter method was adopted by us in most cases [4]. A certain amount of results of higher importance will be quoted on next pages:

A The Hvítá river at Gullfoss' profile

Temperature-precipitation-runoff relations for estimation (forecast) of the discharged volume during the first part of winter (October to December).

Antecedent period: weeks of the wateryear No 44 till 4
(July to September, approximatively)

Current period: weeks No 5 to 17 (October to December, approx.)

- y ... (dependent variable) discharged volume in G1 during the current period
 x_1 ... (independent variable) precipitation index during the current period. The Haell' records of precipitation were taken as this index
 x_2 ... degree-day value during the current period (this value was obtained on base of Haell' records provided that the transforming method for a 630 m elevation has been adopted)
 x_3 ... discharged volume in G1 during the antecedent period
 x_4 ... precipitation index during the antecedent period (Haell' precipitation records)

Two approximation steps were used and the result of this procedure is presented on Fig. 18 (graphically) and in the following schematic equation (mathematically)

$$y = f(x_1, x_3) + f(x_4) + f(x_2) + R$$

The original data used in that procedure are collected in table 16 together with other values.

The deviations of the points (plotted on the lowest part of the Fig. 18, the x_2 -variable against) from the elected dotted curve present the unpredictable rests in single years that may be reffered to as the error or unpreciseness of the relation obtained.

Making use of statistical eleboration of these deviations, we are getting the following values:

mean deviation ... 115 G1
 standard deviation ... 155 G1

The coefficient of variation could be roughly estimated at a 20 per cent value. (the term "coefficient of variation" is used as the synonym for the "relative standard deviation")

To improve this relatively high percentage, a more suitable precipitation index had to be adopted: that's just why we shall use another precipitation index (from Thingvellir' records, namely) in the case next:

B The same relations as that just discussed,
except:

- x_1 ... precipitation index during the current period.
The Thingvellir' records of precipitation (table 17) were adjusted to that of Haell according to the relation-lines drawn on Fig. 17.
- x_4 ... precipitation index during the antecedent period.
The same procedure was used to interpret the measured precipitation at Thingvellir into the conditions of the Haell-region.

Then, using the former developed relations as origin, new relations were carried out between the five variables. The second (and final) step of approximation is presented on Fig. 19.

The statistical characteristics of these new relations, viz.

mean deviation ... 75 G1

standard deviation ... 129 G1

and the coefficient of variation ... 16 per cent, are a little better than the former ones. It may be taken for granted that much more precise relations could be computed, if any reliable precipitation index from the actual catchment area of Gullfoss' section were at hand. (It has to be mentioned in this relation that neither the Haell' nor the Thingvellir' station is located within the area required.)

C The Hvítá river at Gullfoss' section.

Temperature-precipitation-runoff relations for estimation (forecast) of the future discharged volume (during October only)

Antecedent period: water year's weeks No 44 to 4

Current period: weeks No 5 to 8, incl.

Used signs (Fig. 20) (Table 18)

y ... discharged volume in G1 during the current period

x_1 ... precipitation index during the current period
(expressed as the sum of the precipitation records at Haell and Thingvellir)

- x_2 ... degree-day value during the current period
(computed on base of Haeli' temperature records
transformated from a 130 m elevation to the
630 m one)
- x_3 ... discharged volume during the antecedent period
(in G1)
- x_4 ... precipitation index during the antecedent period
(sums of values got at Haeli and Thingvellir stations)

The deviation characteristics, interesting from statistical point of view, are:

mean deviation ... 11 G1
standard deviation ... 14 G1
coefficient of variation ... 6 per cent, approx.

This result of the one months-in advance - forecasting gives quite good satisfaction, even when the precipitation index taken was not so reliable as desired.

D The Hvítá river at Gullfoss' section

Temperature-precipitation-runoff relations for discharged volume forecast in the second half of winter, issued on the end of December (Fig. 21).

Antecedent periods: wateryear's weeks 44 to 17 or
5 to 17, respectively

Current period: weeks 18 to 34 (period January to April, approximately)

The signs used, viz. the " y, x_1, x, \dots, x_5 " symbols are explained at the bottom of the table 16. The x_5 -values are taken from a shorter period only, in consequence of the negligible importance of degree-day values during the relatively warm summer period.

In second alteration (Fig. 22), the restricted number of variables is taken under consideration, the degree-day values x_2 and x_5 being neglected.

There are the following statistical characteristics obtained:

	full number of variables	restricted number of variables
mean deviation	61 G1	87 G1
standard deviation	77 G1	127 G1
coefficient of variation	8 per cent	13 per cent

E The Tungufljót river at Faxi station

Temperature-precipitation-runoff relations for discharged volume estimation in both the first and second halves of winter (Fig. 23, 24)

These forecasting relations are based on use of the same methods as used earlier. All symbol explanations are put in the table 19. No remarkable influence of the x_2 -variable was found in the first-half-of-winter relations.

Statistical values:

	weeks 5 to 17	weeks 18 to 34
mean deviation	8 G1	9 G1
standard deviation	16 G1	21 G1
coefficient of variation	5 %	5 %

F The Brúará river at Dynjandi station

To obtain the similar relations as in the cases going before, the values from the table 20 and the many times discussed known graphical methods were used (Fig. 25, 26)

Final evaluating statistic numbers are as follows:

	relation issued for weeks	
	5 to 17	18 to 34
mean deviation	7 G1	23 G1
standard deviation	11 G1	44 G1
coefficient of variation	3 %	6 %

5.34 Discussion

All the relations quoted are quite suitable for the purposes of discharged volume estimations in advance. It has to be said, however, that a larger amount of more suitable basic records would give better values of the preciseness indexes, namely these of variance.

This look-up-procedure can be carried out using the records of suitably distributed meteorological stations on the one hand and maybe any results of representative snow courses in addition on the other. The influence of the latter values would become a little greater in higher altitudes (e.g. in the upper Thjórsá river basin above Nordlingaalda in the saddle between the two greatest Icelandic glaciers) if spring runoff forecast were under consideration. The hard, tiring and expensive collecting of suitable snow-water-content-records, however, would not be in any comparison with the almost negligible and disputable fraction of per cent got as the improvement of forecast preciseness.

Example 5 The Hvítá river at Gullfoss' cross-section.

Discharged volume forecast for the period from January to April (weeks No 18 to 34) is to be carried out on the last days of December (using the relations presented graphically on Fig. 21)

The following data from antecedent period are at hand

- (x_3) discharged volume (at Gullfoss), weeks 44 to 17,
... 1900 G1
- (x_4) total sum of precipitation (at Haell) weeks 44 to 17,
... 400 mm
- (x_5) degree-day value (Haell temperature records transformed), weeks 5 to 17, ... 70°C-day

The two other variables are unpredictable in the moment of forecast-making, than only theirs statistical estimations as e.g. the guaranteed or most expected values can be taken in account, namely

(x_1) future total sum of precipitation (at Haell),
 weeks 18 to 34,
 guaranteed minimum 170 mm; the most expected mean value
 320 mm

(x_2) future degree-day value, weeks 18 to 34
 guaranteed minimum 20°C day; most expected value 100°C day

The guaranteed minimum and the most probable expected mean
 value forecast (from Fig. 21)

$f(x_1, x_3)$ + 1055 G1	(+ 1095)
$f(x_4)$ + 115 G1	(+ 115)
$f(x_2)$ - 215 G1	(- 35)
$f(x_5)$ + 45 G1	(+ 45)
Σ	+ 1000 G1	(+ 1220)
$\pm 1,645.0,08. \Sigma$ <u>± 130 G1</u>	<u>(± 160)</u>

y varies from 870 to 1130 G1 and from 1060 to
 1380 G1

From the standpoint of power generation guaranty in the
 future period considered, making use of the 90 per cent
 probability as the deciding value for the possible
 accuracy evaluation, -

the 870 G1-value is to be referred to as the forthcoming
 season, and

the 1060 G1-value can be taken in account as the lowest of
 the range of most expected coming mean
 discharged volumes

Provided that no forecasting relations had been carried
 out, we should be obliged to accept the lowest observed
 value (525 G1 taken from table 16) as that which will not
 to be undergone.

The difference between the two "almost perfectly guaranteed"
 values (namely $345 = 870 - 525$) should be considered as the
 net profit of this forecast-making.

Example 6 The restricted number of variables shall be used for the task, described in the example 5 (Fig. 22):

	guaranteed minimum	the most expected value
$f(x_1, x_3)$ + 1125 G1	(+ 1195 G1)
$f(x_4)$ + 65 G1	(+ 65 G1)
Σ	+ 1190 G1	(+ 1260 G1)
$\pm 1,645.0, 13. \Sigma$ <u>± 255 G1</u>	<u>(± 270 G1)</u>
y varies from	935 to 1445 G1	and from 990 to 1530 G1

The meaning of all signs and numbers obtained is the same as that discussed in the antecedent example. In relation to that, the latter wider limits of estimation refer to a worse accuracy of these "restricted" values.

In conclusion of both these examples, 5 and 6, we should like to give the reader to understand, that several values have been roughly estimated only because of insufficient extent of values required for more exact computations. The examples mentioned have been described mainly with a view to present the method used.

5.4 Conclusions

The temperature-precipitation-runoff relations have been adopted for the solution of the river forecastings in the Hvítá and Thjórsá river basins.

The relations found are quite suitable for the purposes of discharged volume estimations in advance. The groundwater feeding of the Icelandic rivers mentioned above makes the seasonal forecasting possible. It shall have a great importance in the storage exploitation for the power generation during winter.

After using a larger amount of more suitable basic observations, better values of the accuracy will be obtained. Due to present lack of suitable meteorological records from the areas investigated, the unpreciseness of relations got is a little higher but still in allowable limits, eventhough the basic data have had to be taken from remote stations,

the location and exposure of which have not been as good as required.

The seasonal forecast as explained above is going to play for an important part in the programming of the optimum exploitation of impounded water. It will be of use if any suitable number of meteorological stations will be established and observed to improve the preciseness as well as the reliability of the forecasts.

6 REFERENCES

a) general description

- [1] БЕФАНИ Н. Ф.,
КАЛИНИН Г. П.,

БЕРНАНИ N.F.,
KALININ G.P.,

УПРАЖНЕНИЯ И МЕТОДИЧЕСКИЕ РАЗРАБОТКИ
ПО ГИДРОЛОГИЧЕСКИМ ПРОГНОЗАМ,
ГИМИЗ, ЛЕНИНГРАД, 1965

Hydrological Forecast Drills and
Methodical Treatment, Hydrometeo-
rological Publishing House,
Leningrad, 1965
(in Russian)
- [2] CHOW, VEN TE

Handbook of Applied Hydrology,
McGraw-Hill Book Company, 1964
- [3] DUB, O.

Hydrológia, hydrografia, hydrometria,
SVTL Bratislava, 1967
Hydrology, Hydrography, Hydrometry,
Slovak Technical Publishing House,
Bratislava, 1957
(in Slovak)
- [4] LINSLEY, RAY K., Jr.,
KOHLER, MAX A.,
PAULHUS, JOSEPH L.H.

Applied Hydrology,
McGraw-Hill Book Company,
Kogakusha Company, 1949

b) special problems

- [5] BRATRÁNEK, A.,

Výzkum hydrologických charakteristik
s ohledem na možnost zásobování vodou
VÚV Praha, 1964
Research of Hydrological Characteri-
stics with Regard to Possibilities
of Water Supply,
Hydraulic Research Institute,
Praha, 1964
(with summary in Russian and English)

[6] MARTINEC, J.,

Krátkodobé prognózy jarních
průtoků na základě teploty,
Vodohospodářský časopis XI, 4, 1965
SAV Bratislava

Short-term Forecasts of Spring Run-
off on Ground of Temperature,
Vodohospodářský časopis XI, 4, 1965
Slovak Academy of Sciences' Publi-
shing House, Bratislava

(with summary in Russian and English)

[7] PROCHÁZKA, J.

Kurzfristige Durchflussmengen-
vorhersage im oberen Waag-Abfluss-
gebiet,

III. Konferenz der Donau-gebietstaaten
über hydrologische Vorhersagen,
Bucuresti, Mai 1965

Short-term Forecast of Discharged
Volumes in the Upper Basin of the
Váh River,

3rd Hydrological Forecasts Assembly
of the Danube River Basin Countries,
Bucuresti, May 1965

(with summary in French and Russian)

7 LIST OF EXHIBITS

7.1 Figures

- Fig. 1 Key map of the Hvítá and Thjórsá river basins
- Fig. 2 The Hvítá river - Development of the drainage area
- Fig. 3 The Thjórsá river - Development of the drainage area
- Fig. 4 The Hvítá river - Longitudinal section
- Fig. 5 The Thjórsá river - Longitudinal section
- Fig. 6 The Hvítá river - Hypsographic curves
- Fig. 7 The Thjórsá river - Hypsographic curve
- Fig. 8 The Hvítá river at Gullfoss station - Forecast of guaranteed discharged volume (based on past records of discharges only)
- Fig. 9 The Hvítá river at Gullfoss section - Deviations/moment of forecast relation
- Fig. 10 The Hvítá river at Gullfoss station - Relation between two successive yearly volumes of discharge
- Fig. 11 The Tungufljót river at Faxi station - Forecast of guaranteed discharged volume, based on past records of discharges only
- Fig. 12 - Deviations/moment of forecast relation
- Fig. 13 The Brúará river at Dynjandi section - Forecast of guaranteed discharged volume
- Fig. 14 - Deviation/moment of forecast relation
- Fig. 15 Degree-day/temperature relation
- Fig. 16 Thingvellir/Haell degree-day relations
- Fig. 17 Thingvellir/Haell precipitation relations
- Fig. 18 The Hvítá river at Gullfoss section - Temperature-precipitation-runoff relations for discharged volume estimations (OCT. to DEC.)
Records from Gullfoss (hydrol.) and Haell (meteorol.)
State after the second step of approximation
- Fig. 19 The Hvítá river at Gullfoss section - Temperature-precipitation-runoff relations for discharged volume forecasts (OCT. to DEC.)
Records from Gullfoss (hydrol.), Thingvellir (precip.) and Haell (degree-days)

- Fig. 20 The Hvítá river at Gullfoss section - Temperature-precipitation-runoff relations for discharged volume forecasts (in OCTOBER only)
Records from Gullfoss (hydrol.) Thingvellir and Haell (precip.) and Haell (degree-days)
State after the third approximation step
- Fig. 21 The Hvítá river at Gullfoss section - Temperature-precipitation-runoff relations for discharged volume forecasts (JAN. to APRIL)
Records from Gullfoss (hydrol.) and Haell (meteorol.)
State after the second step of approximation
- Fig. 22 The Hvítá river at Gullfoss section - Precipitation-runoff relations for discharged volume forecasts (JAN. to APRIL - period)
Restricted number of variables (without any regard to temperature indexes)
- Fig. 23 The Tungufljót river at Faxi station - Temperature-precipitation-runoff relations for discharged volume forecasts (OCT. to DEC.)
Records from Faxi and Haell (meteorol.)
- Fig. 24 The Tungufljót river at Faxi station - Temperature-precipitation-runoff relations for discharged volume forecasts (JAN. to APRIL)
Records from Faxi (hydrol.) and Haell (meteorol.)
- Fig. 25 The Brúará river at Dynjandi station - Temperature-precipitation-runoff relations for discharged volume forecasts (OCT. to DEC.)
Records from Dynjandi (hydrol.), Thingvellir (precip.) and Haell (temper.)
- Fig. 26 The Brúará river at Dynjandi station - Temperature-precipitation-runoff relations for discharged volume forecasts (JAN. to APRIL)
Records from Dynjandi (hydrol.), Thingvellir (precip.) and Haell (temperature)

7.2 Tables

- Table 1 The Hvítá river system - Characteristic values
- Table 2 The Thjórsá river system - Characteristic values
- Table 3 The Hvítá river at Gullfoss station - Progressive sums of monthly discharged volumes, forward computed
- Table 4 The same, backward computed
- Table 5 The Hvítá river at Gullfoss station - Actual deviations from the guaranteed discharged volume forecasts
- Table 6 The Hvítá river at Gullfoss section - Test of the forecasting method
- Table 7 The Tungufljót river at Faxi section - Progressive sums of monthly discharged volumes, forward computed
- Table 8 - , backward computed
- Table 9 The Tungufljót river at Faxi station - Deviations from the guaranteed discharged volume forecasts
- Table 10 The Brúará river at Dynjandi station - Progressive sums of monthly discharged volumes, forward computed
- Table 11 - , backward computed
- Table 12 The Brúará river at Dynjandi station - Deviation from the guaranteed discharged volume forecasts
- Table 13 The Brúará river at Dynjandi station - Test of the forecasting method
- Table 14 Transformation of degree-days values
- Table 15 The degree-days computed
- Table 16 The Hvítá river at Gullfoss section - List of initial data used for the carrying out of several relations (e.g. Fig. 18, 19, 21, 22)
- Table 17 Precipitation at Thingvellir (used in relations as that of the Fig. 19, 25, 26)
- Table 18 The Hvítá river at Gullfoss section - List of initial data used for several relations (see e.g. Fig. 20)
- Table 19 The Tungufljót river at Faxi station - List of initial data used for the carrying out of several relations (see e.g. Fig. 23, 24)
- Table 20 The Brúará river at Dynjandi cross-section - List of initial data used for the elaboration of several relations (see Fig. 25, 26)

Fig.1

Main Storages

- I Hvítárvatn reservoir
- II Nordlingaalda reservoir
- III Þorísvatn
- IV Stórisjór reservoir
- V Langisjór

Main Water gauges

- The Hvítá river
- 2 Ljósafoss
- 41 Iða
- 43 Dynjandi
- 57 Hvítárbrú
- 64 Selfoss
- 68 Faxi
- 87 Gullfoss
- 101 Ábóti
- 107 Árhraun
- The Thjórsá river
- 30 Urriðafoss
- 94 Vað
- 95 Sauðafell
- 97 Tröllkonuhlaup
- 98 Hald
- 99 Háifoss
- 100 Norðlingaalda

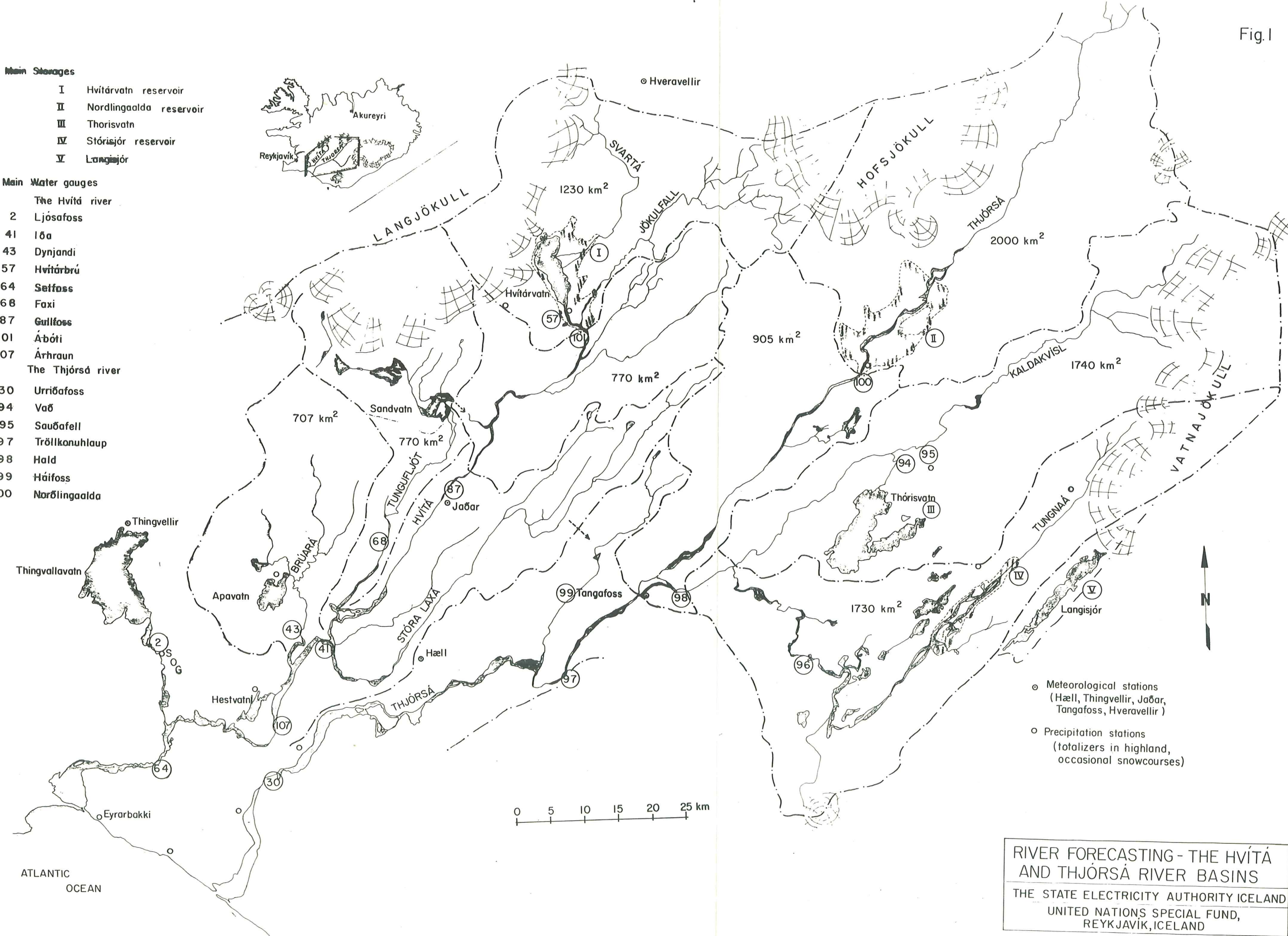

RIVER FORECASTING - THE HVÍTÁ AND THJÓRSÁ RIVER BASINS
 THE STATE ELECTRICITY AUTHORITY ICELAND
 UNITED NATIONS SPECIAL FUND, REYKJAVÍK, ICELAND

Fig. 2

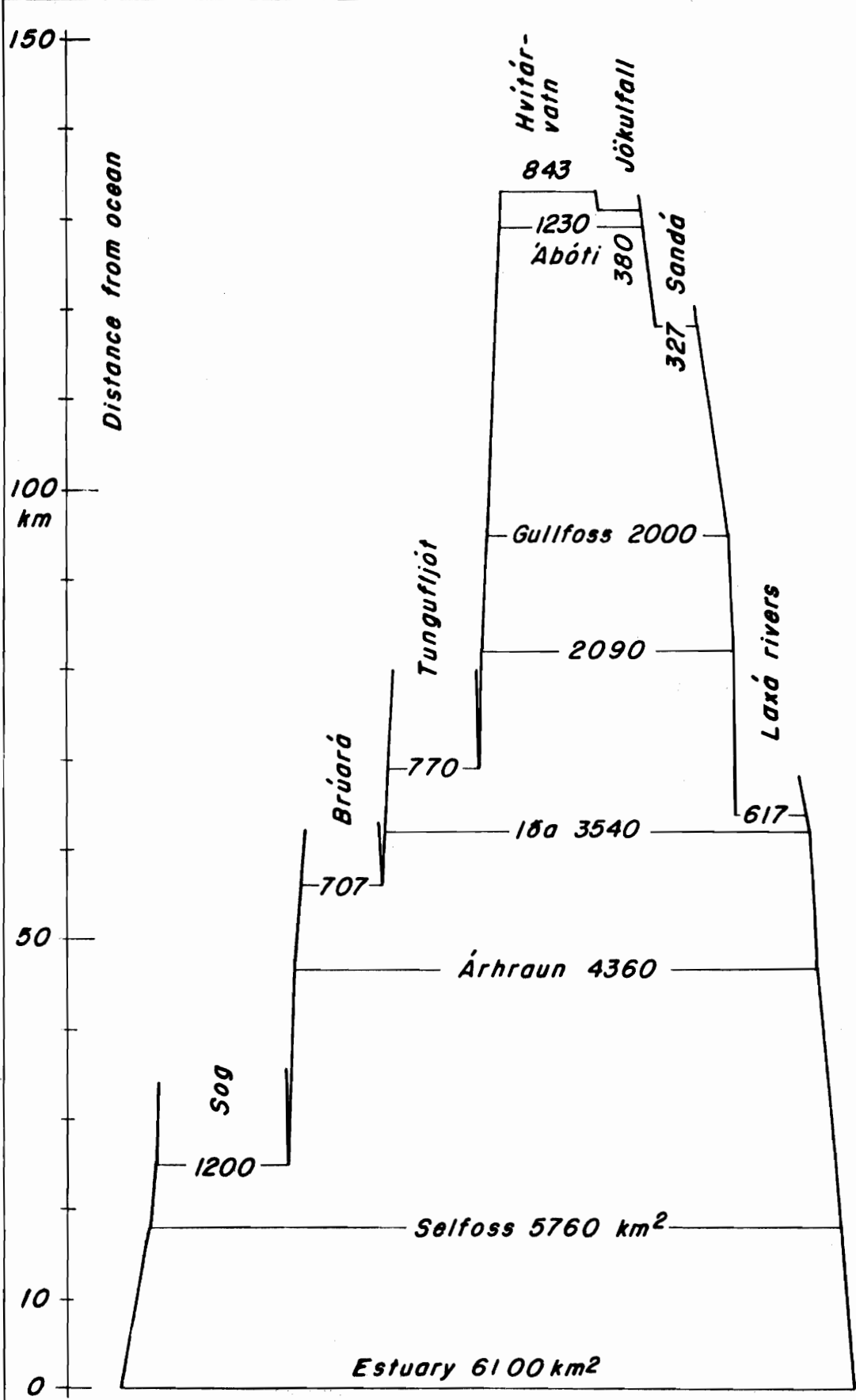

RIVER FORECASTING - THE HVÍTÁ RIVER
 DEVELOPMENT OF THE DRAINAGE AREA
 THE STATE ELECTRICITY AUTHORITY, ICELAND
 UNITED NATIONS SPECIAL FUND, REYKJAVÍK, ICELAND

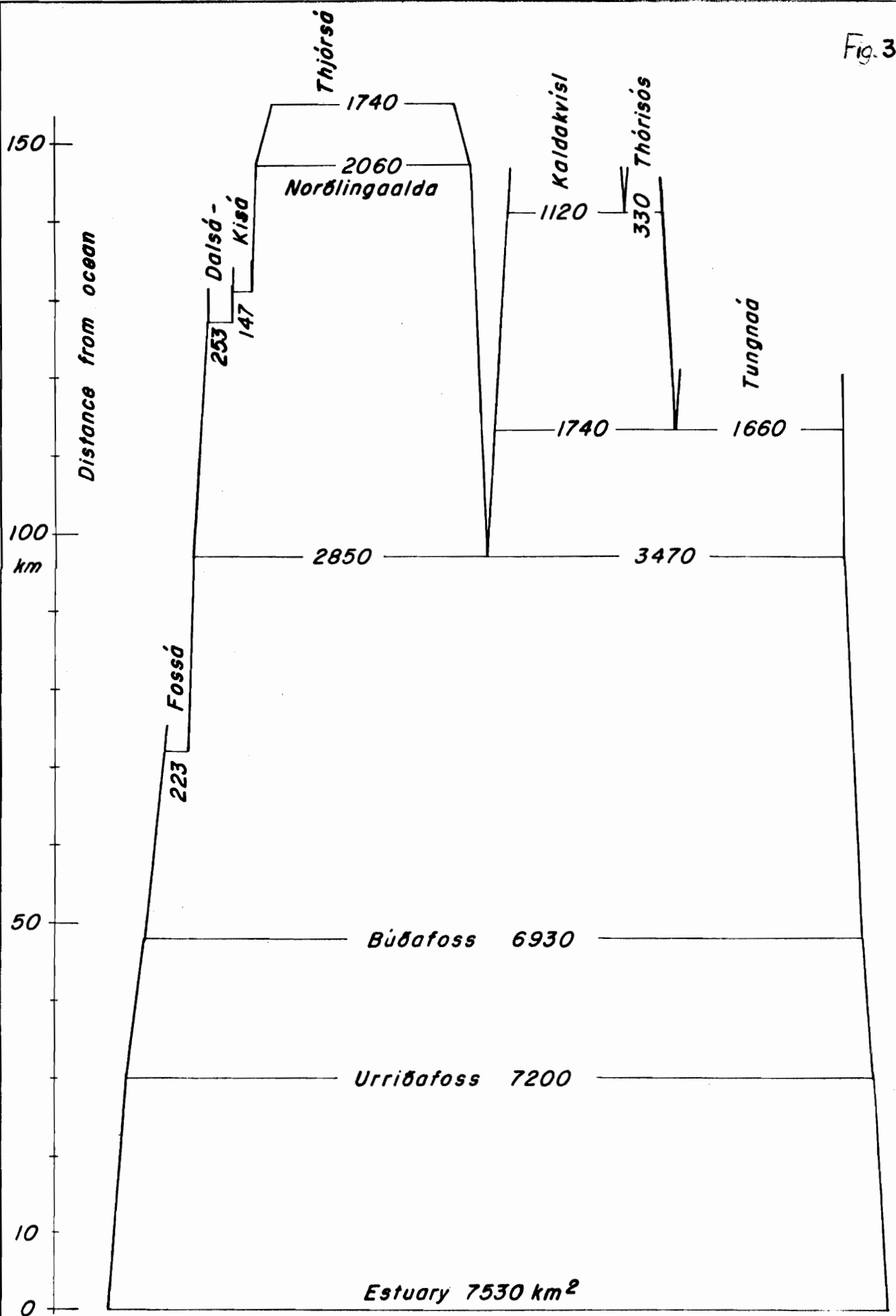

RIVER FORECASTING - THE THJÓRSÁ RIVER
 DEVELOPMENT OF THE DRAINAGE AREA
 THE STATE ELECTRICITY AUTHORITY, ICELAND
 UNITED NATIONS SPECIAL FUND, REYKJAVÍK, ICELAND

Fig. 4

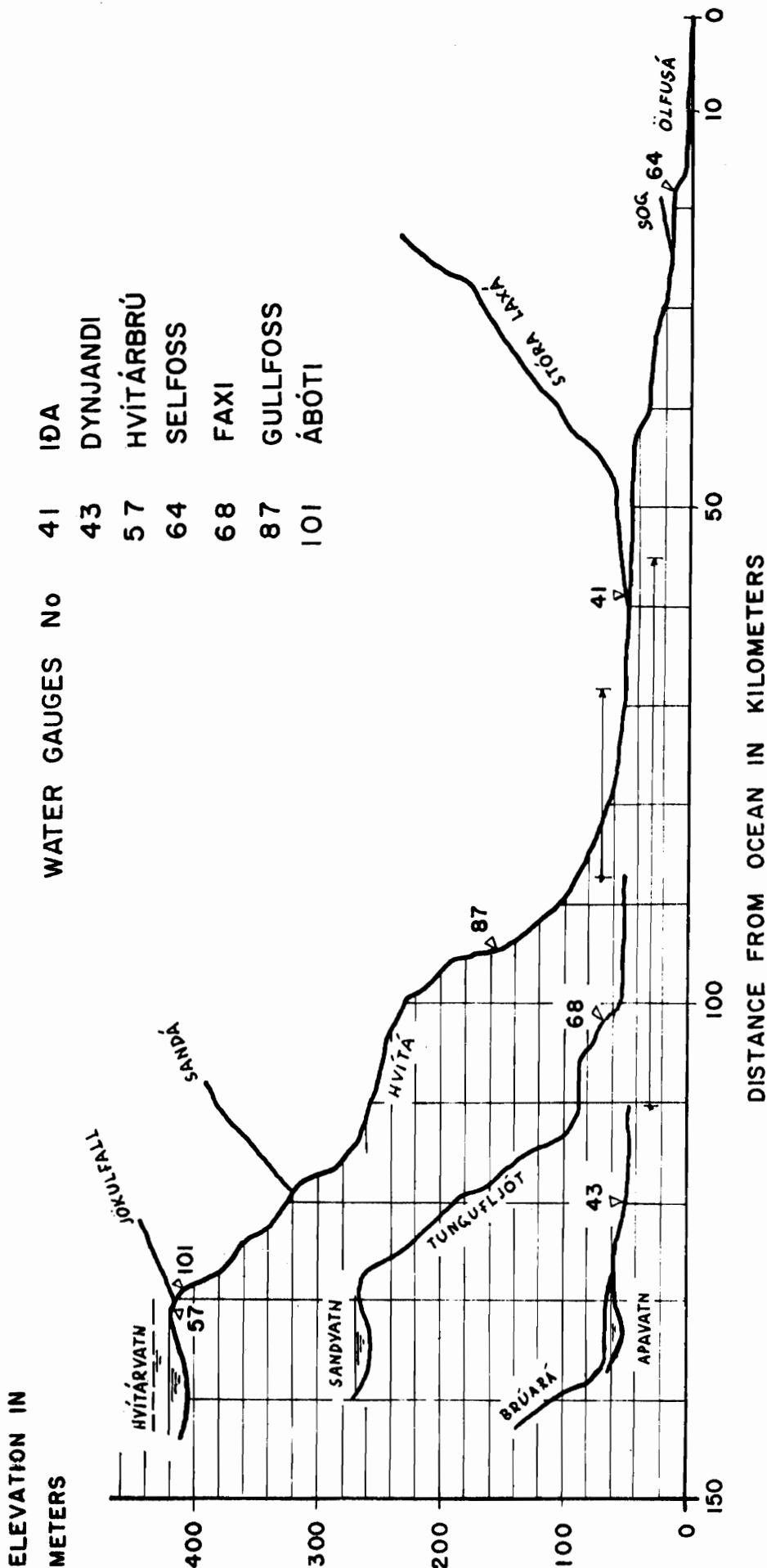

RIVER FORECASTING - THE HVÍTÁ RIVER
LONGITUDINAL SECTION

THE STATE ELECTRICITY AUTHORITY, ICELAND

UNITED NATIONS SPECIAL FUND, REYKJAVÍK, ICELAND

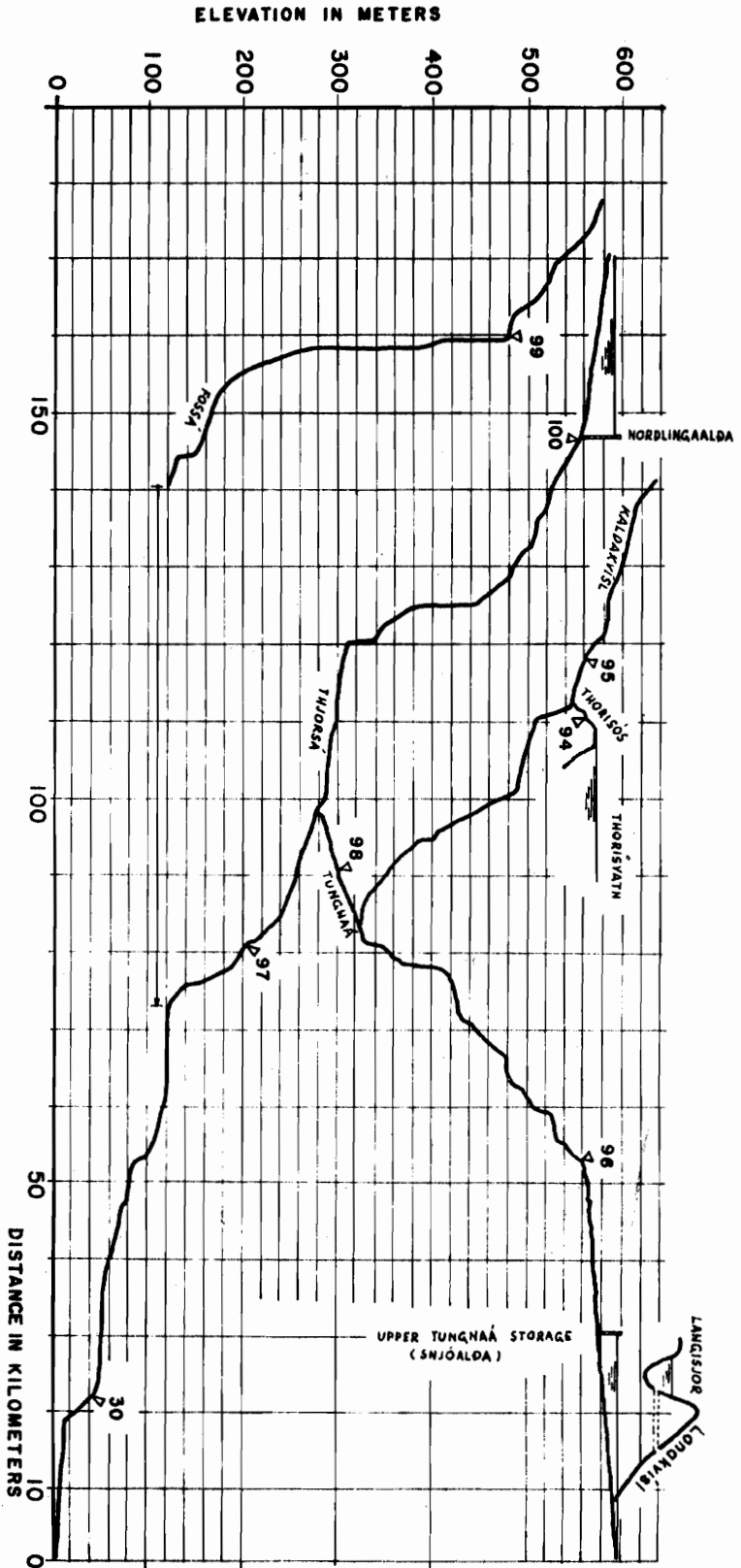

WATER GAUGES

No	Name
30	Urríðafoss
94	Vag
95	Sauðafell
96	Vainnóidur
97	Tröllkonuhlaup
98	Hald
99	Hálfoss
100	Norðlingaöld

RIVER FORECASTING - THE THJÓRSÁ RIVER
 LONGITUDINAL SECTION
 THE STATE ELECTRICITY AUTHORITY, ICELAND
 UNITED NATIONS SPECIAL FUND, REYKJAVÍK, ICELAND

Fig. 5

Fig. 6

Elevation
above
sea level

Total (Earthsurface) drainage area
of the Hvítá - Ölfusá river

6100 km²

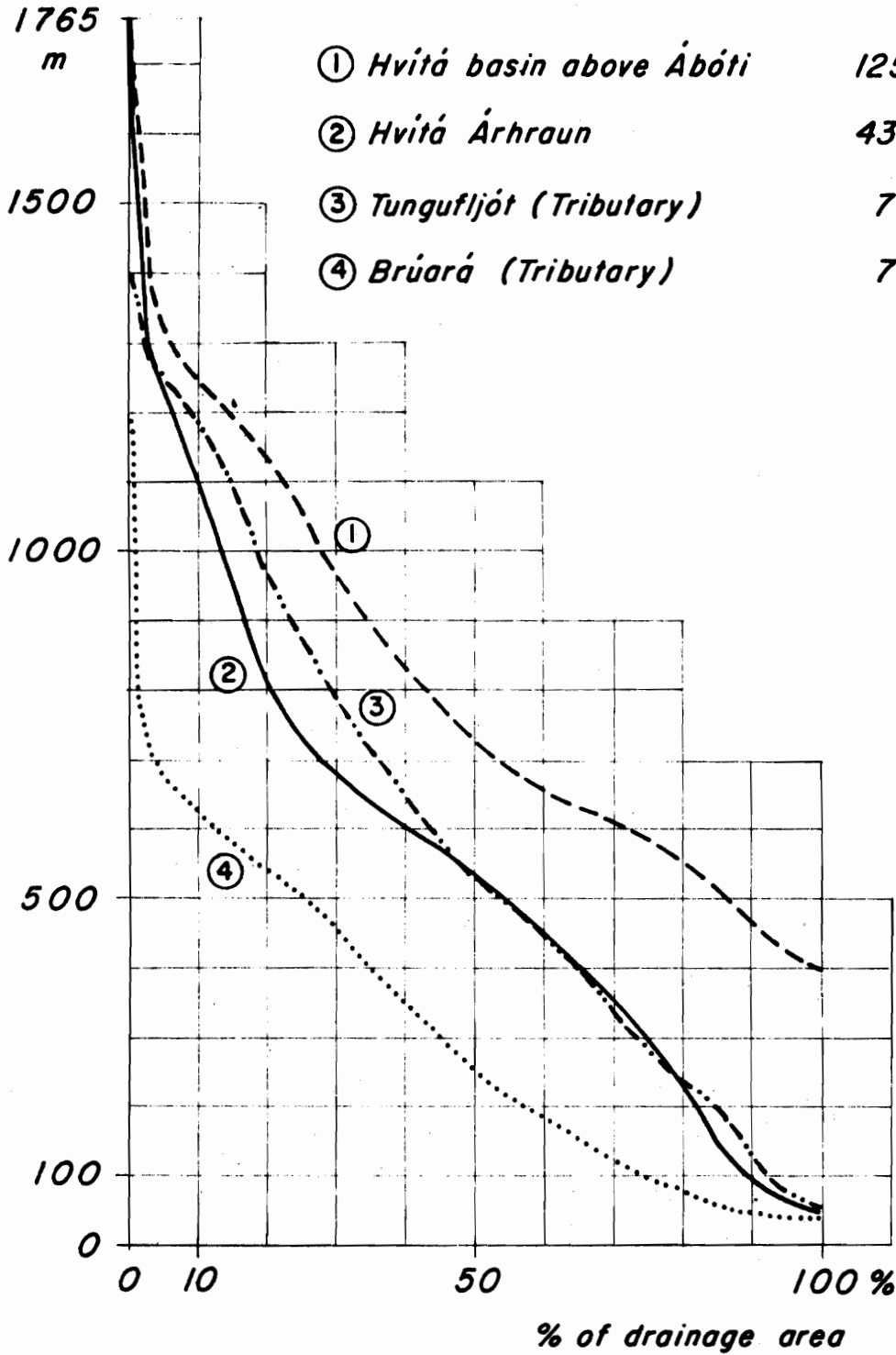

RIVER FORECASTING - HVÍTÁ RIVER BASIN
 HYSOGRAPHIC CURVES

THE STATE ELECTRICITY AUTHORITY, ICELAND

UNITED NATIONS SPECIAL FUND, REYKJAVIK, ICELAND

Altitude
in m

Total drainage area

7530 km²

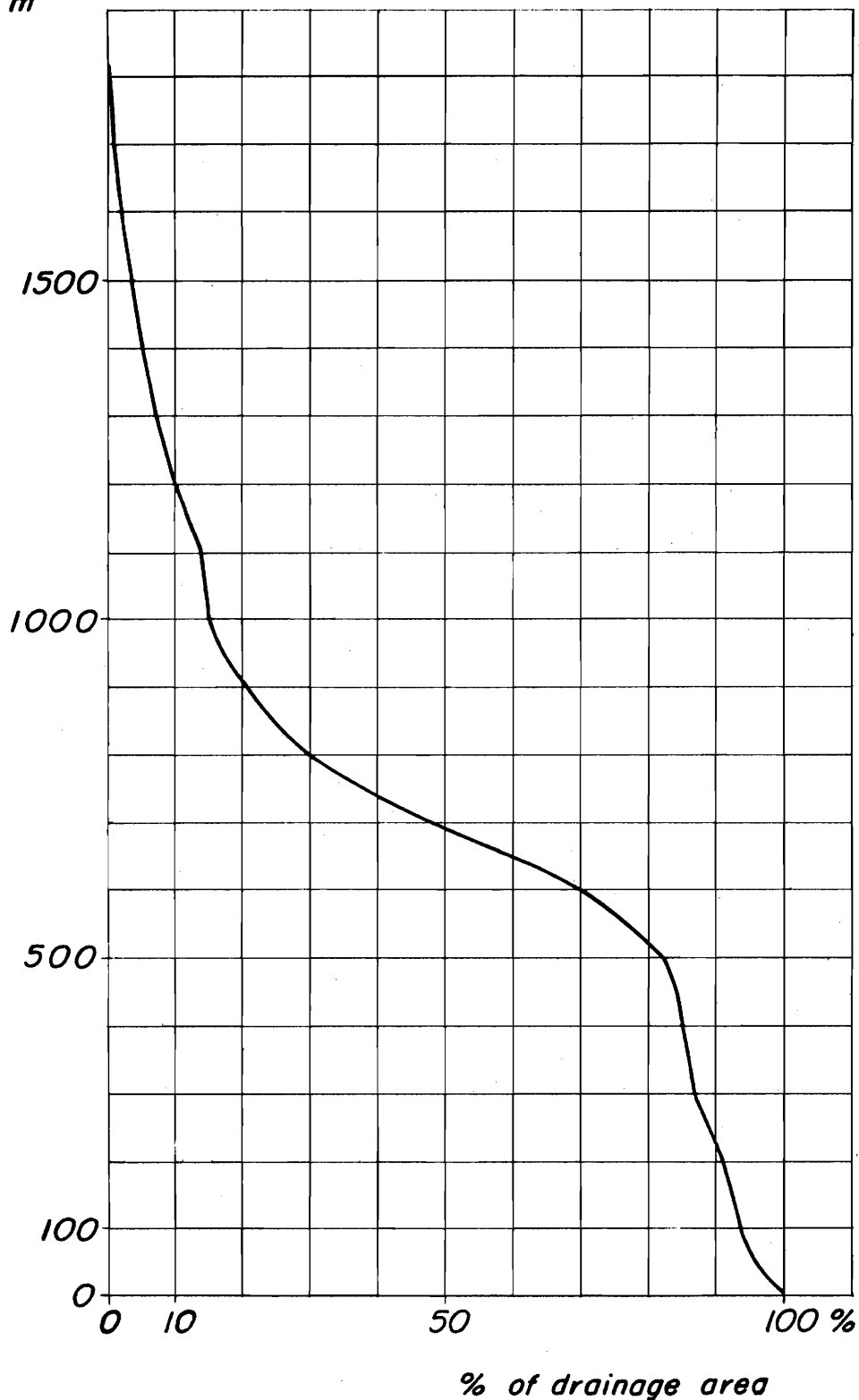

Hypsographic curve

RIVER FORECASTING – THJÓRSÁ RIVER BASIN

THE STATE ELECTRICITY AUTHORITY, ICELAND

UNITED NATIONS SPECIAL FUND, REYKJAVÍK, ICELAND

Fig. 8

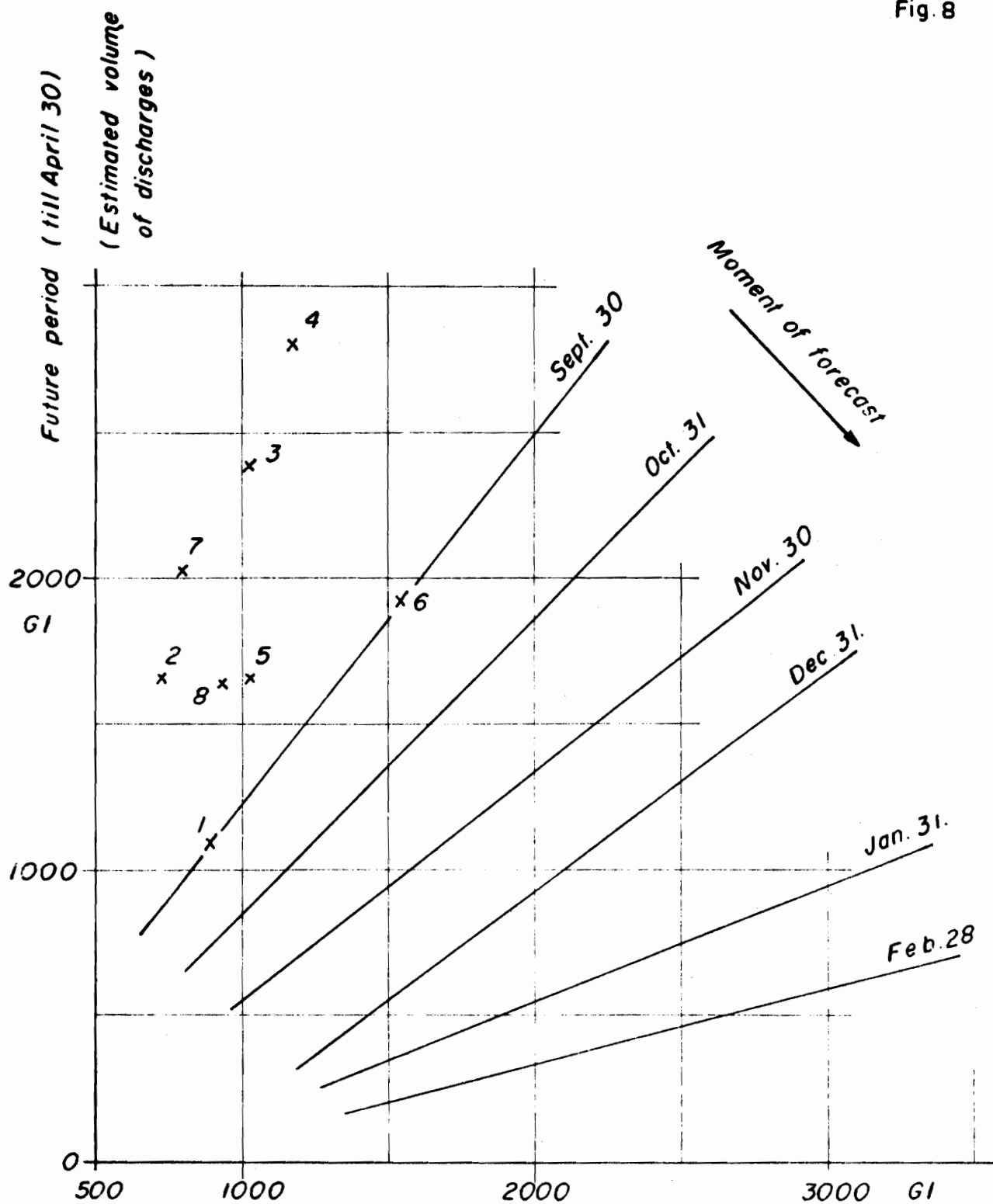

Antecedent period (since July 1)

(known volume of discharges)

(7x ---- actual value in separate wateryears on Sept. 30)

RIVER FORECASTING - THE HVÍTÁ RIVER
 GULLFOSS STATION - FORECAST OF GURANTEED
 DISCHARGED VOLUME (BASED ON PAST RECORDS
 OF DISCHARGES ONLY)

THE STATE ELECTRICITY AUTHORITY, ICELAND

UNITED NATIONS SPECIAL FUND, REYKJAVÍK, ICELAND

*Random part (in %) of actual total volume of discharge
(from Oct.1 to April 30) above the forecasted
guaranteed minimum*

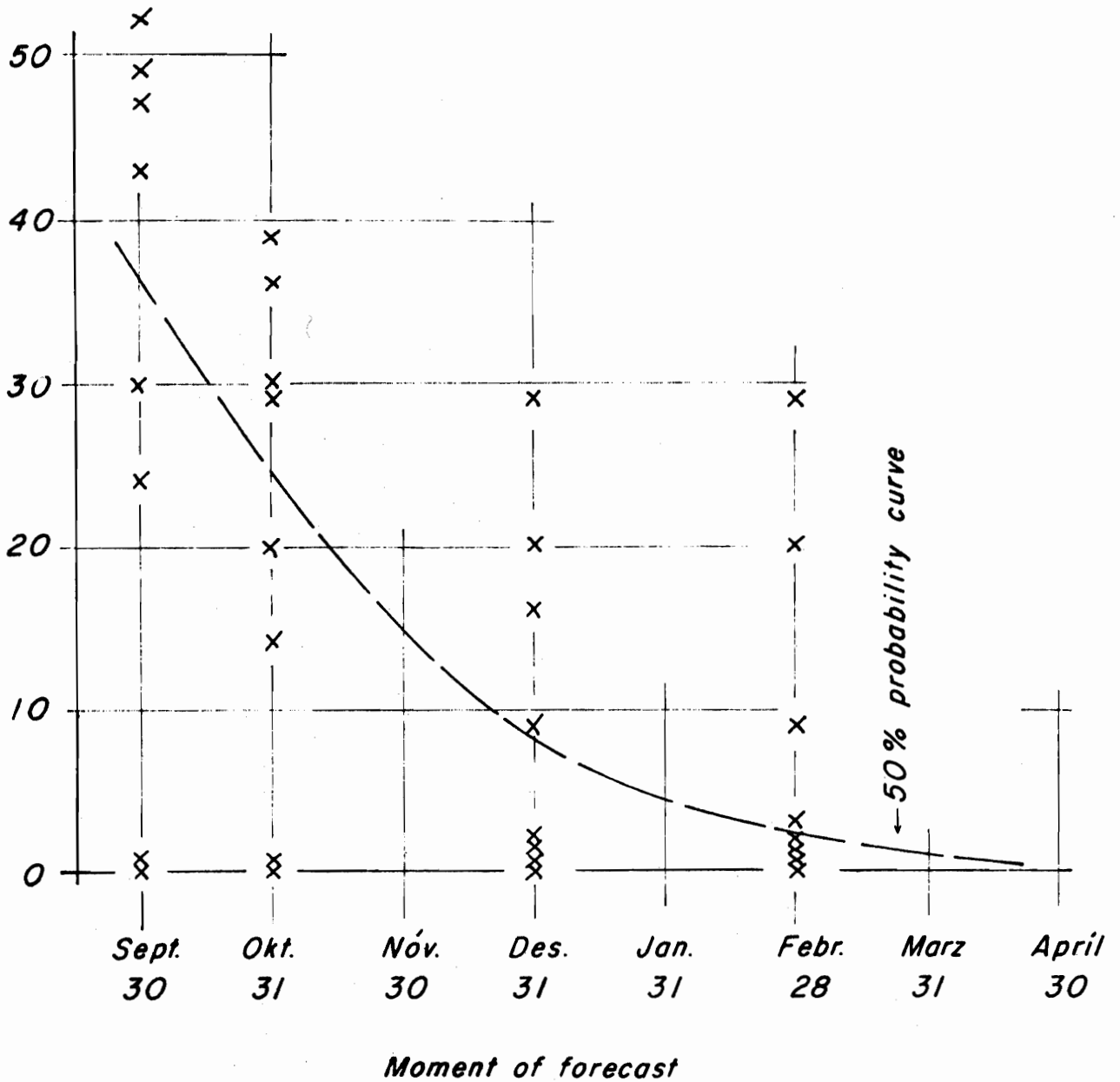

RIVER FORECASTING - THE HVÍTÁ RIVER - GULLFOSS STATION
DEVIATIONS / MOMENT OF FORECAST RELATION

THE STATE ELECTRICITY AUTHORITY, ICELAND

UNITED NATIONS SPECIAL FUND, REYKJAVÍK, ICELAND

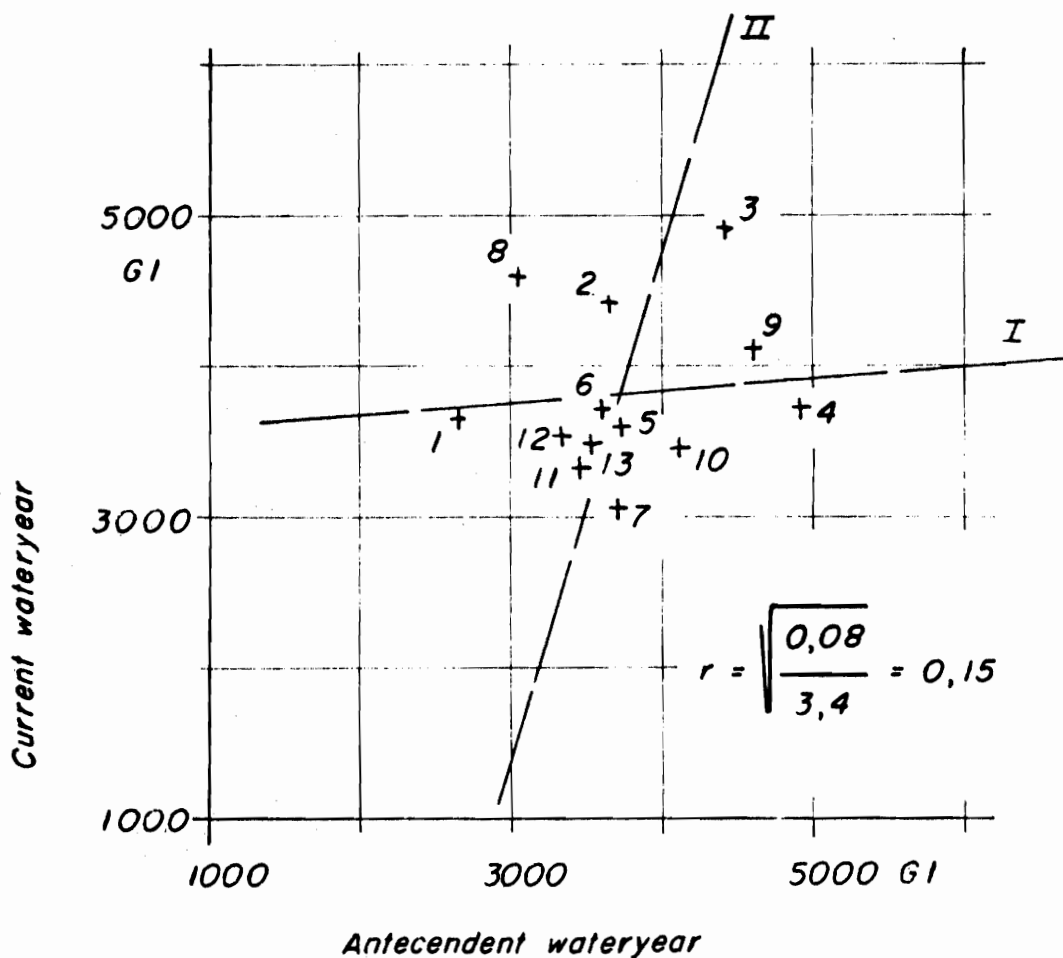

Relation between two successive yearly volumes of discharges

RIVER FORECASTING-THE HVÍTÁ RIVER-GULLFOSS STATION

THE STATE ELECTRICITY AUTHORITY, ICELAND

UNITED NATIONS SPECIAL FUND, REYKJAVÍK, ICELAND

5-34 } *Periods of forecast (in wateryear's weeks)*
 9-34 } *(Guaranteed minimum of discharged volume in the future)*
 13-34 }
 18-34 }
 26-34 }

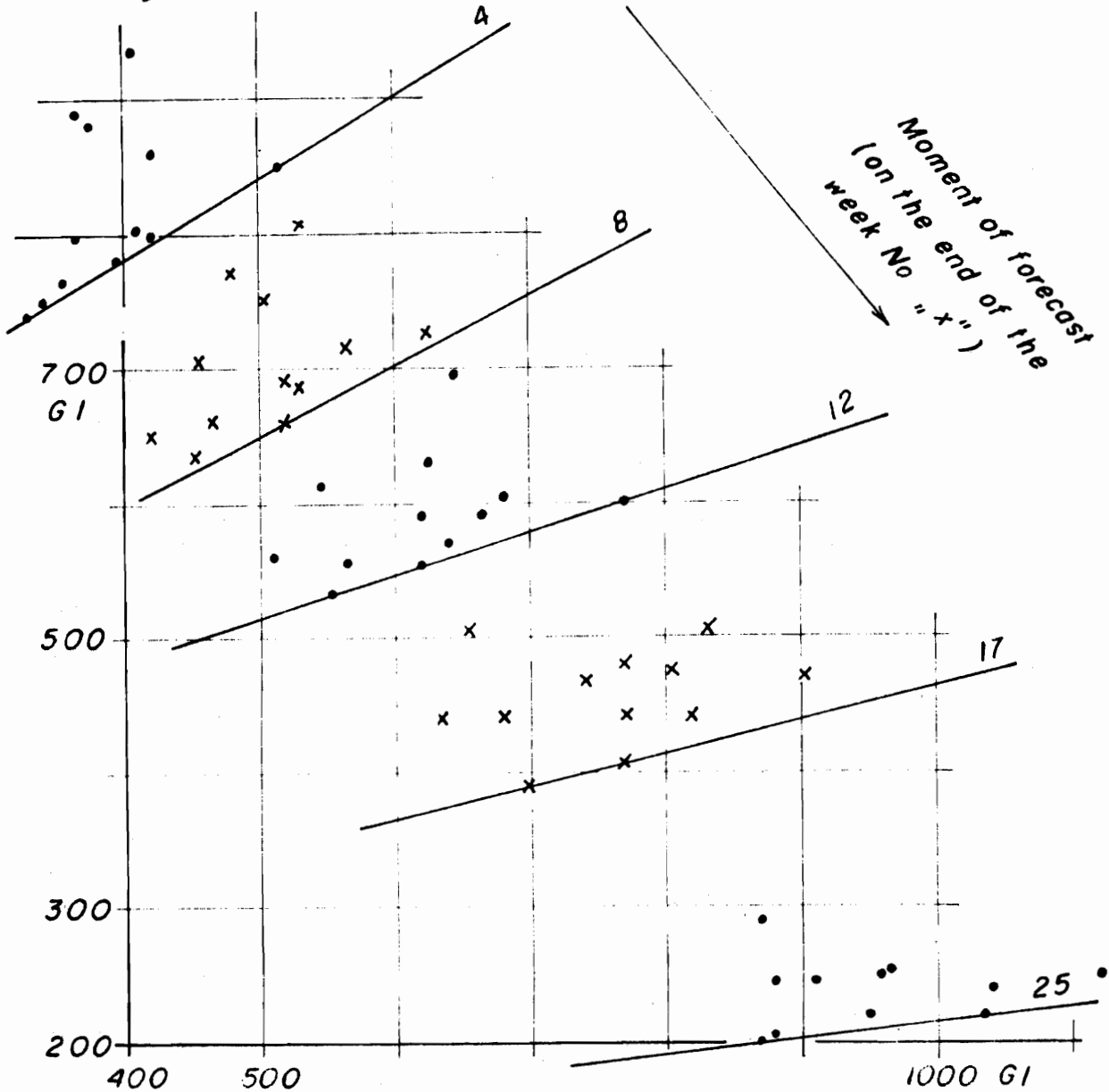

Discharged volume in the antecedent
(known values)

1 GI = 1 mill. m³

period: { 44-4
 44-8
 44-12
 44-17
 44-25 } *Wateryear's weeks (inclus.)*

RIVER FORECASTING - THE TUNGUFLJÖT RIVER
 FAXI STATION - FORECAST OF GUARANTEED
 DISCHARGED VOLUME - BASED ON PAST RECORDS
 OF DISCHARGES ONLY
 THE STATE ELECTRICITY AUTHORITY, ICELAND
 UNITED NATIONS SPECIAL FUND, REYKJAVÍK, ICELAND

Fig. 12

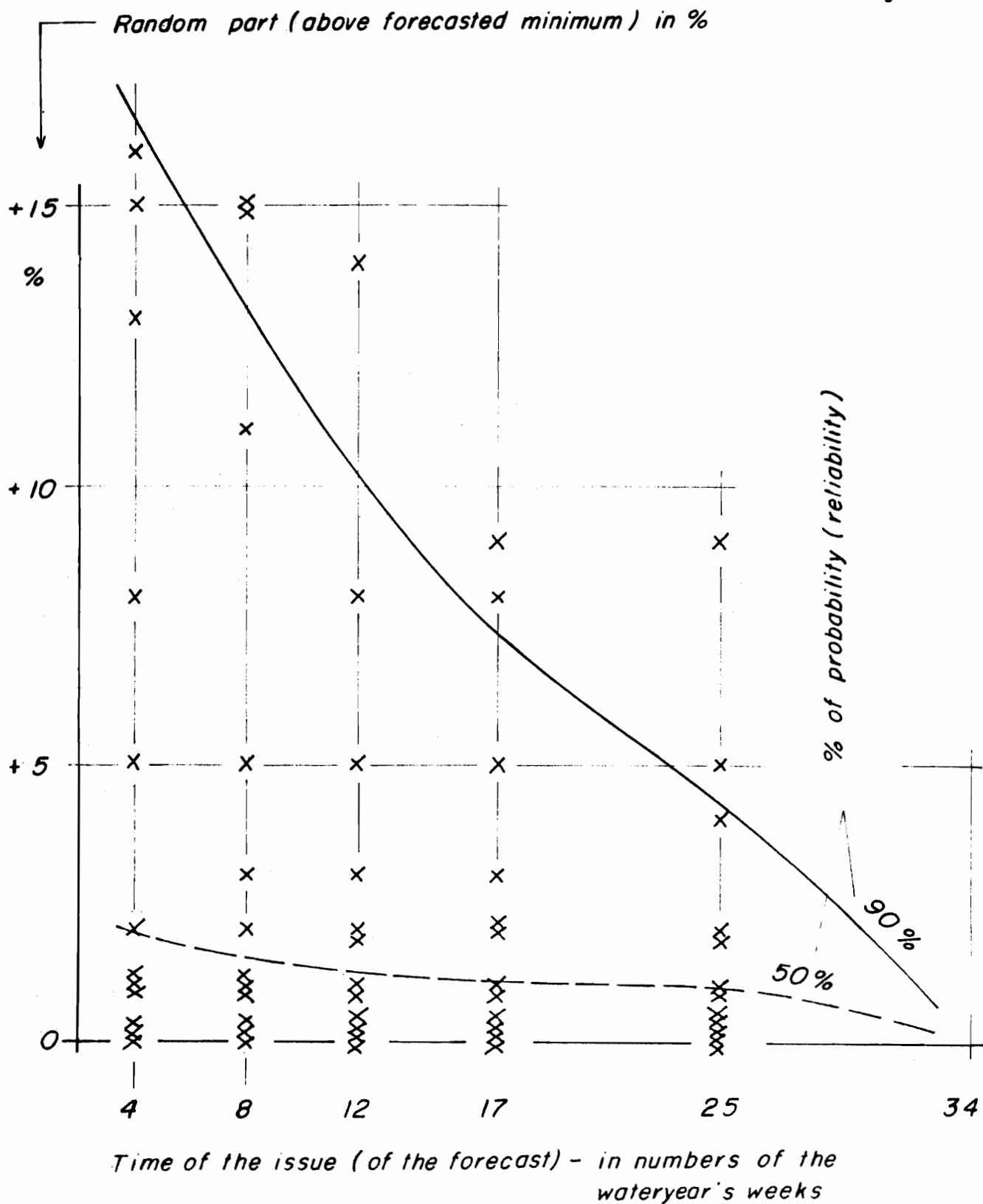

THE TUNGUFLJÓT RIVER - FAXI STATION
 RANDOM PART OF THE DISCHARGED
 VOLUME ABOVE THE FORECASTED
 GUARANTEED MINIMUM
 THE STATE ELECTRICITY AUTHORITY, ICELAND
 UNITED NATIONS SPECIAL FUND, REYKJAVIK, ICELAND

10-4
 11-4
 12-4
 1-4
 2-4
 3-4

Future period in months
(Discharged volume, G1)

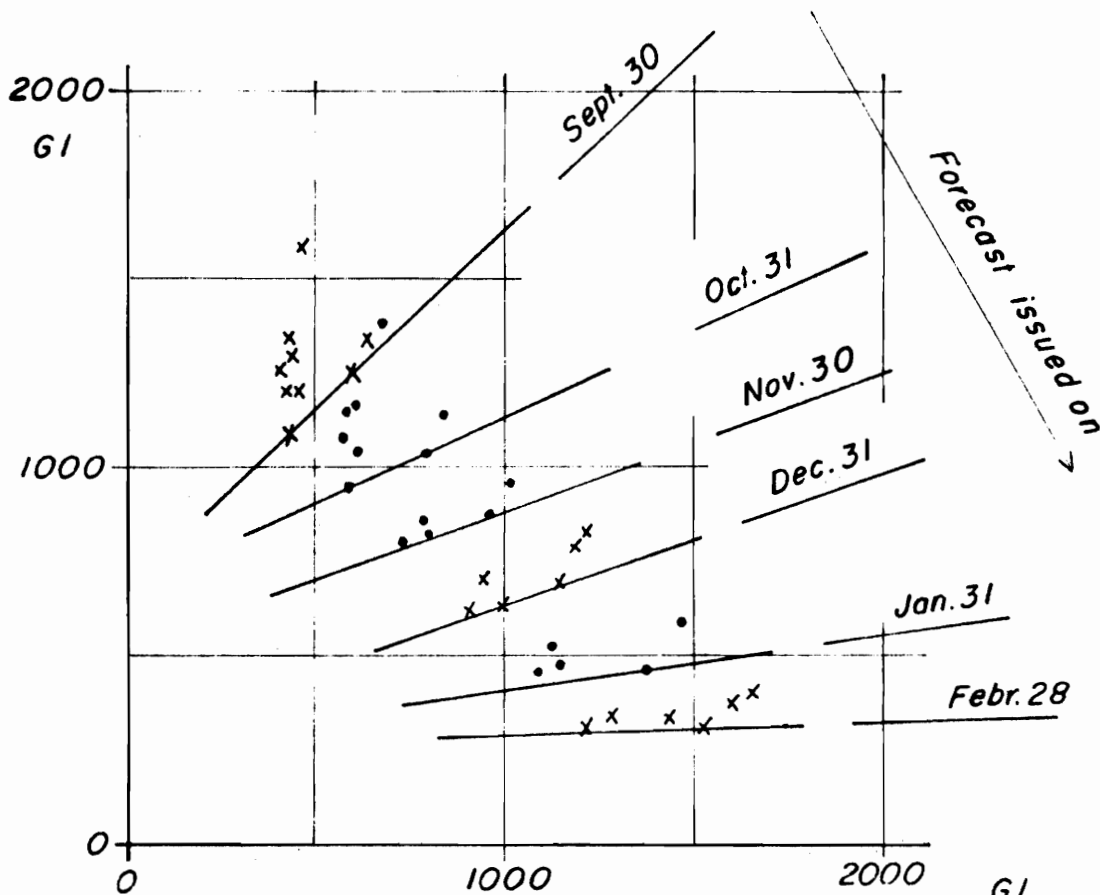

Discharged volume in the antecedent period (in months)

7-9
 7-10
 7-11
 7-12
 7-1
 7-2

RIVER FORECASTING - THE BRÚARÁ RIVER -
 DYNJANDI STATION - FORECAST OF GUARANTEED
 DISCHARGED VOLUME (BASED ON PAST RECORDS
 OF DISCHARGES ONLY)
 THE STATE ELECTRICITY AUTHORITY, ICELAND
 UNITED NATIONS SPECIAL FUND, REYKJAVÍK, ICEL.

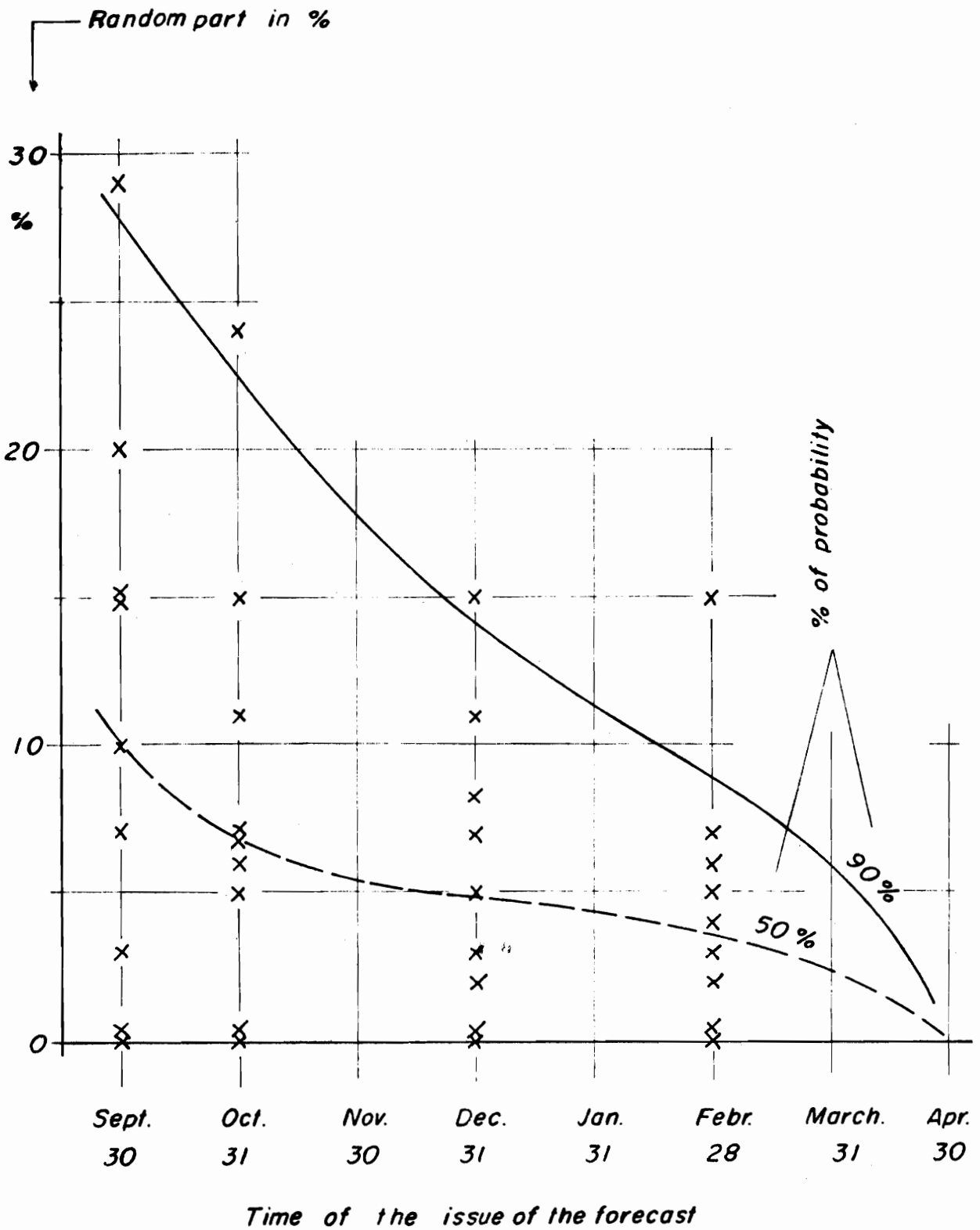

RIVER FORECASTING—THE BRÚARÁ RIVER—
 DYNJANDI STATION—RANDOM PART OF THE
 DISCHARGED VOLUME IN WINTER (OCTOBER TO MAY)
 ABOVE THE FORECASTED GUARANTEED MINIMUM

THE STATE ELECTRICITY AUTHORITY, ICELAND

UNITED NATIONS SPECIAL FUND, REYKJAVÍK, ICELAND

Fig.15

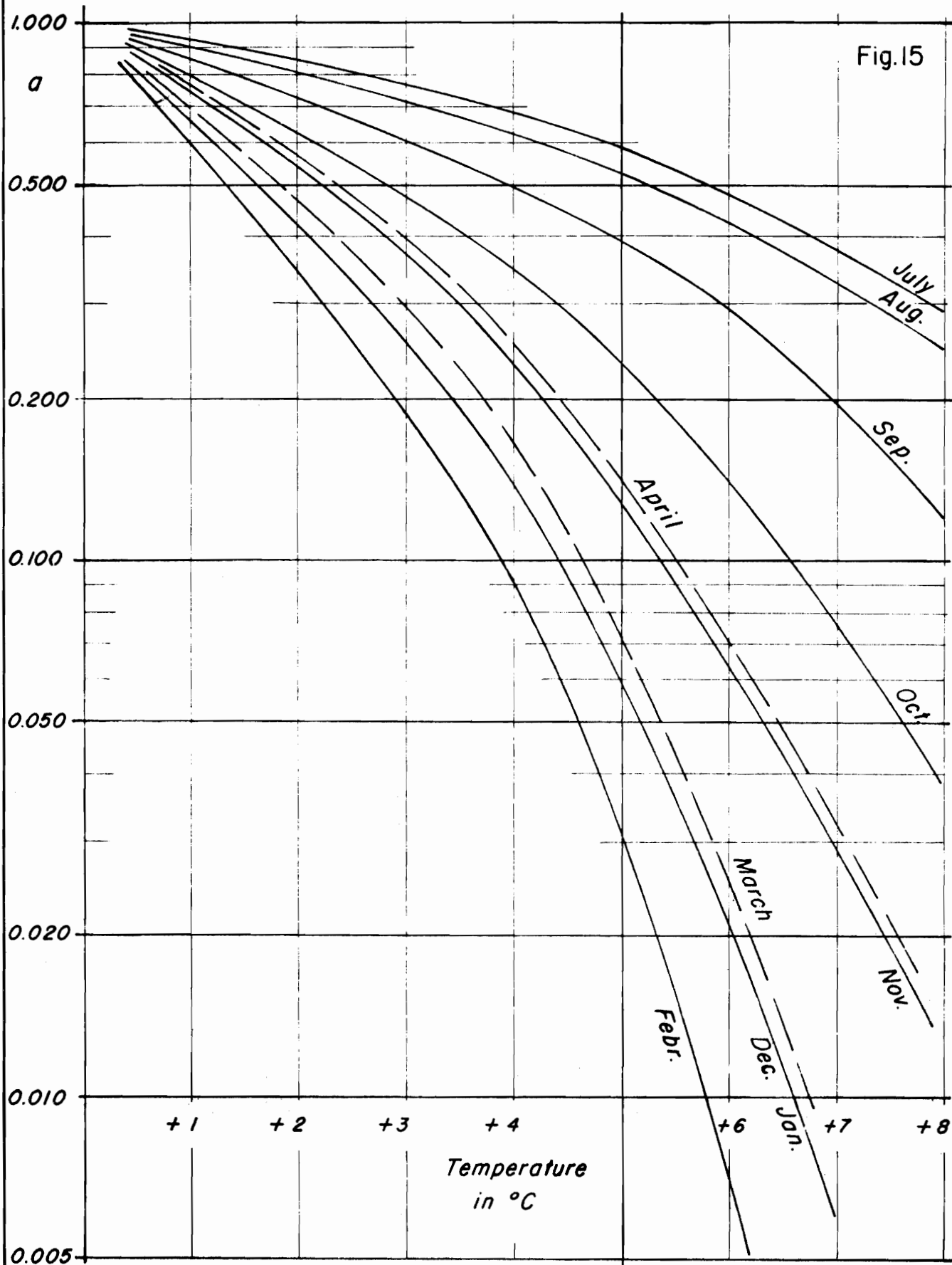

$$DD_1 = a \cdot DD_2 \neq 0$$

(From Hæll-records)

RIVER FORECASTING
DEGREE-DAY/TEMPERATURE RELATION

THE STATE ELECTRICITY AUTHORITY, ICELAND
UNITED NATIONS SPECIAL FUND, REYKJAVÍK, ICELAND

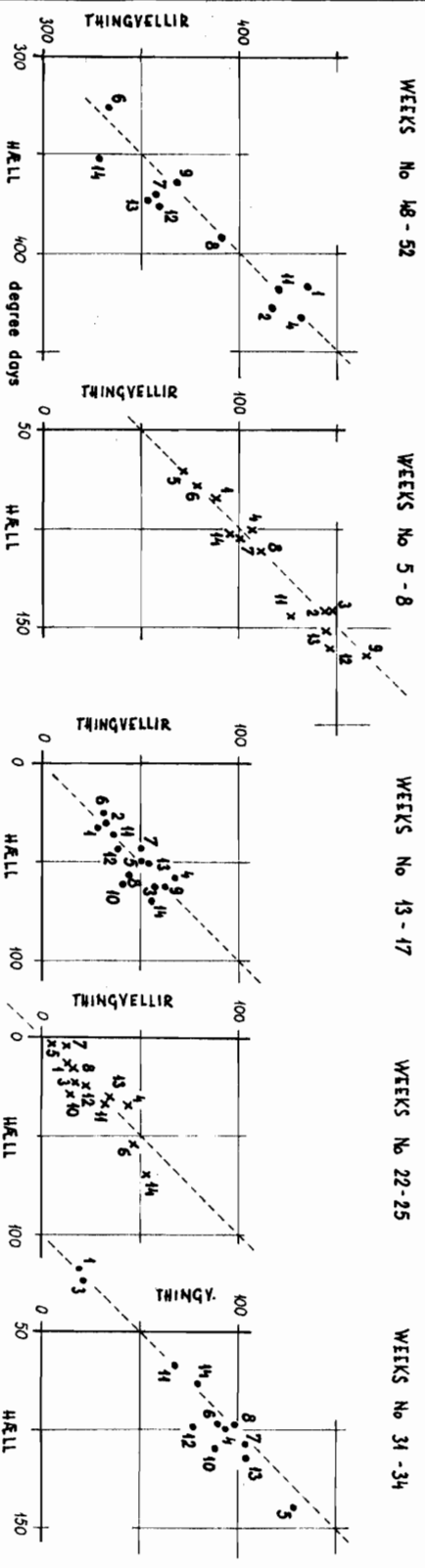
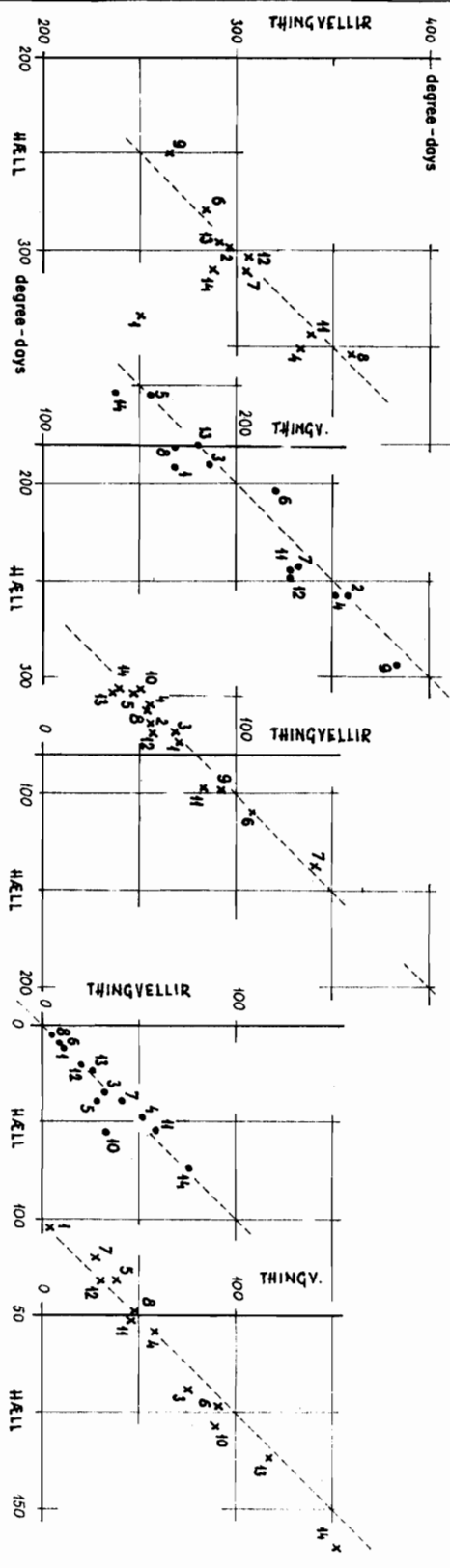

DEGREE-DAY VALUES
FOR $T > 0^{\circ}\text{C}$

NO OF WEEK ----
--- ACCORDING TO WATERYEAR
(BEGINNING ON SEPT 1)

NO. OF WATERYEAR ----
1 = 1950/51
2 = 51/52

Fig. 16
Sheet 2 of 2

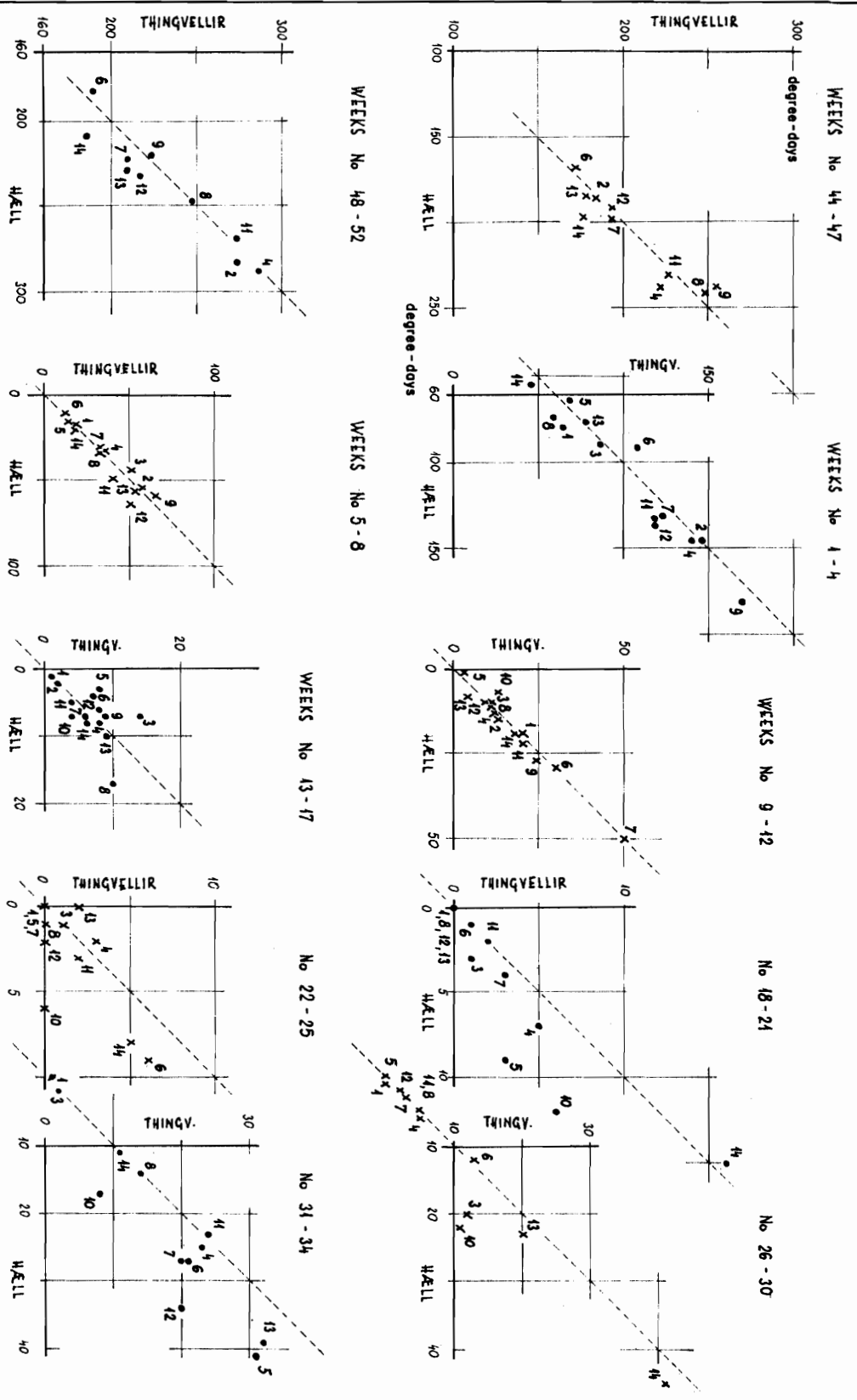

DEGREE - DAYS VALUES
FOR T > 4°C

NO. OF WEEK -----
-----ACCORDING TO WATERYEAR
(BEGINNING ON SEPT 1)

NO. OF WATERYEAR----
1 = 1950/51
2 = 1951/52

RIVER FORECASTING
THINGVELLIR/HÆLL DEGREE-DAYS RELATION
THE STATE ELECTRICITY AUTHORITY, ICELAND
UNITED NATIONS SPECIAL FUND, REYKJAVIK, ICELAND

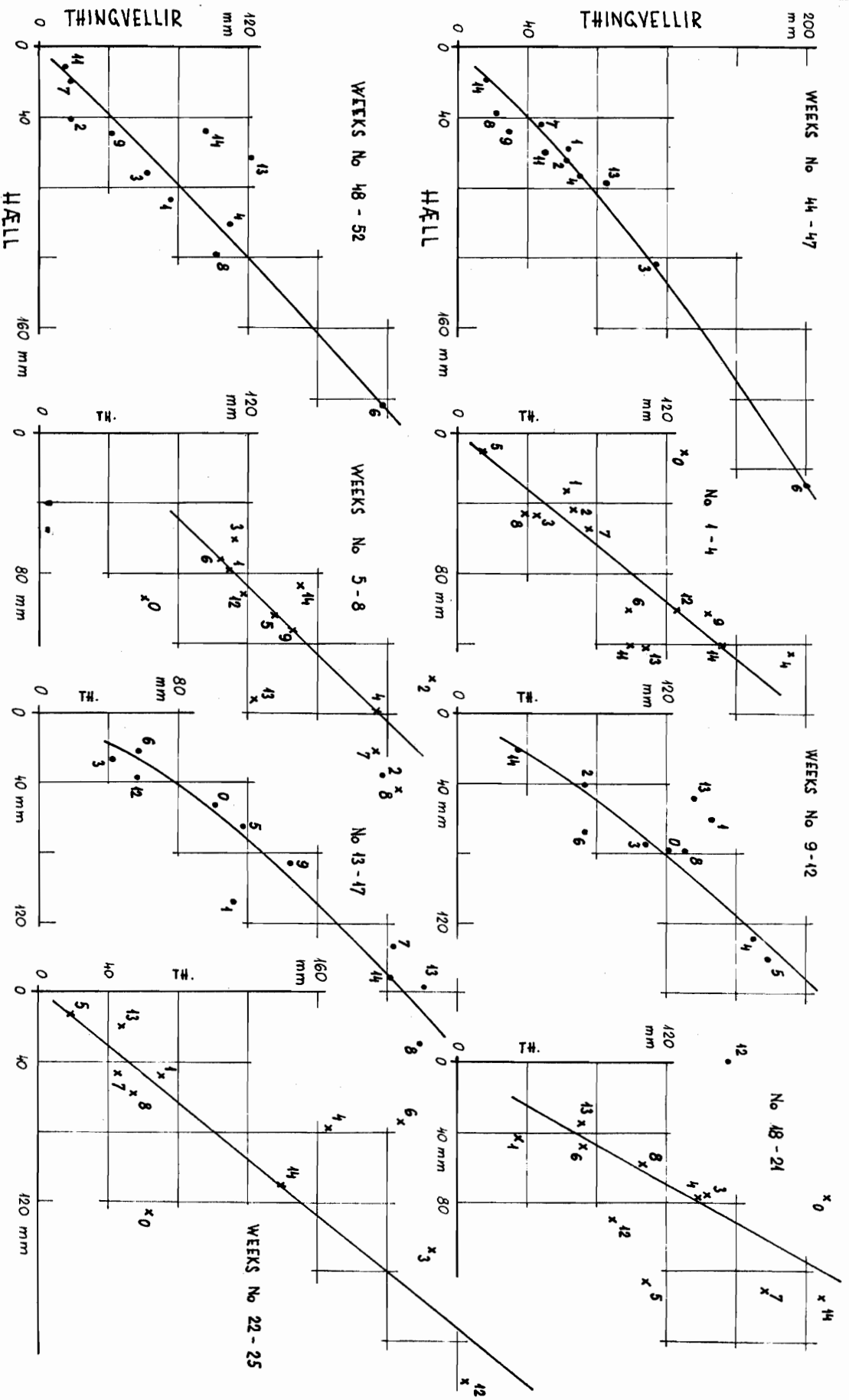
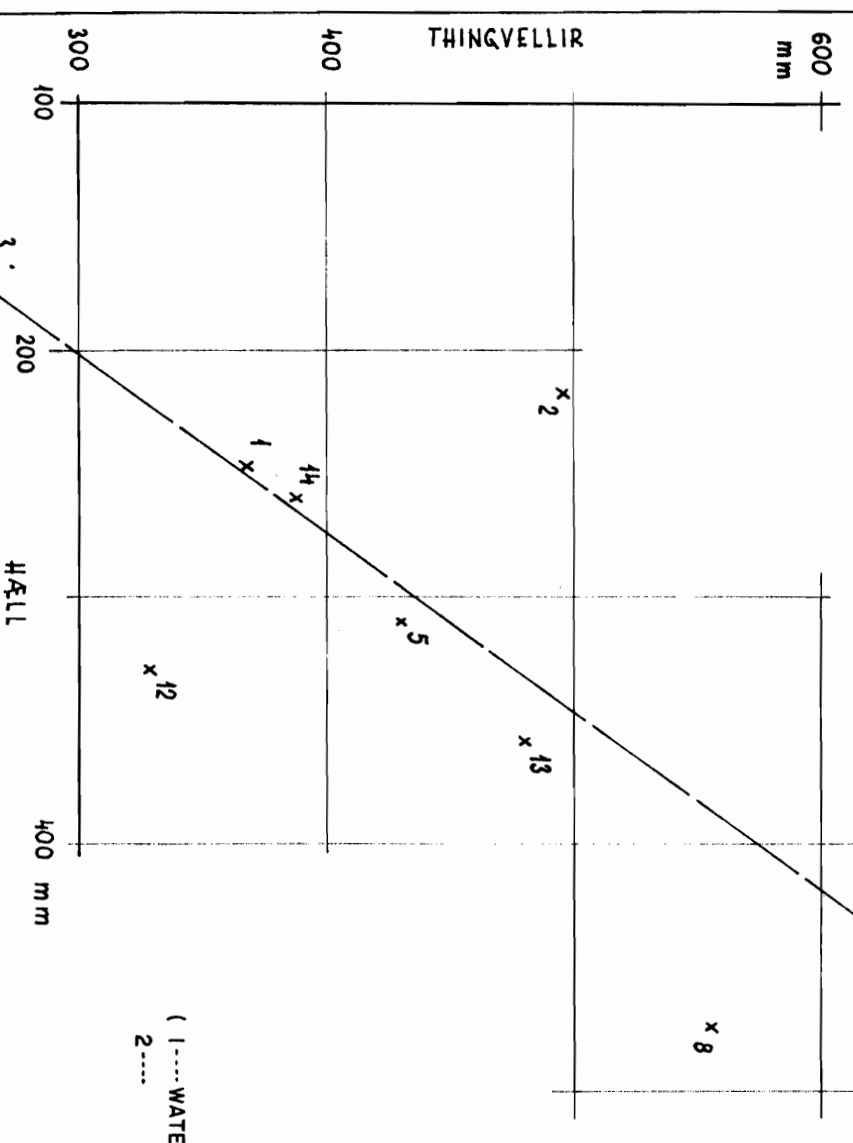

Fig 17
Sheet 1 of 3

NO. OF WEEK ----- ACCORDING TO
WATERYEAR (BEGIN ON SEPT. 1)

NO. OF YEAR ----- | = 1950/51
2 = 1951/52 ----

WEEKS No 5-17
 OCTOBER TO DECEMBER, APPROX.



WEEKS No 14-4
 JULY TO SEPTEMBER, APPROX.

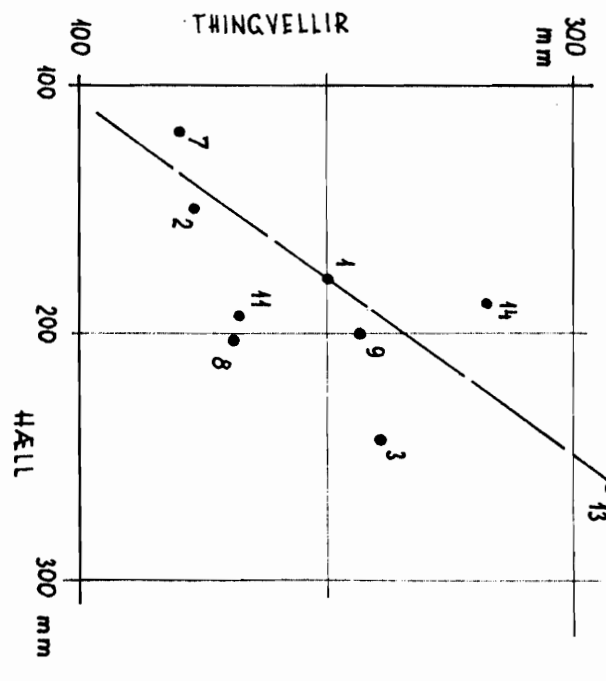

(..... WATERYEAR 1950/51
 2 51/52)

Fig 17
 Sheet 2 of 3

Fig. 17
Sheet 3 of 3

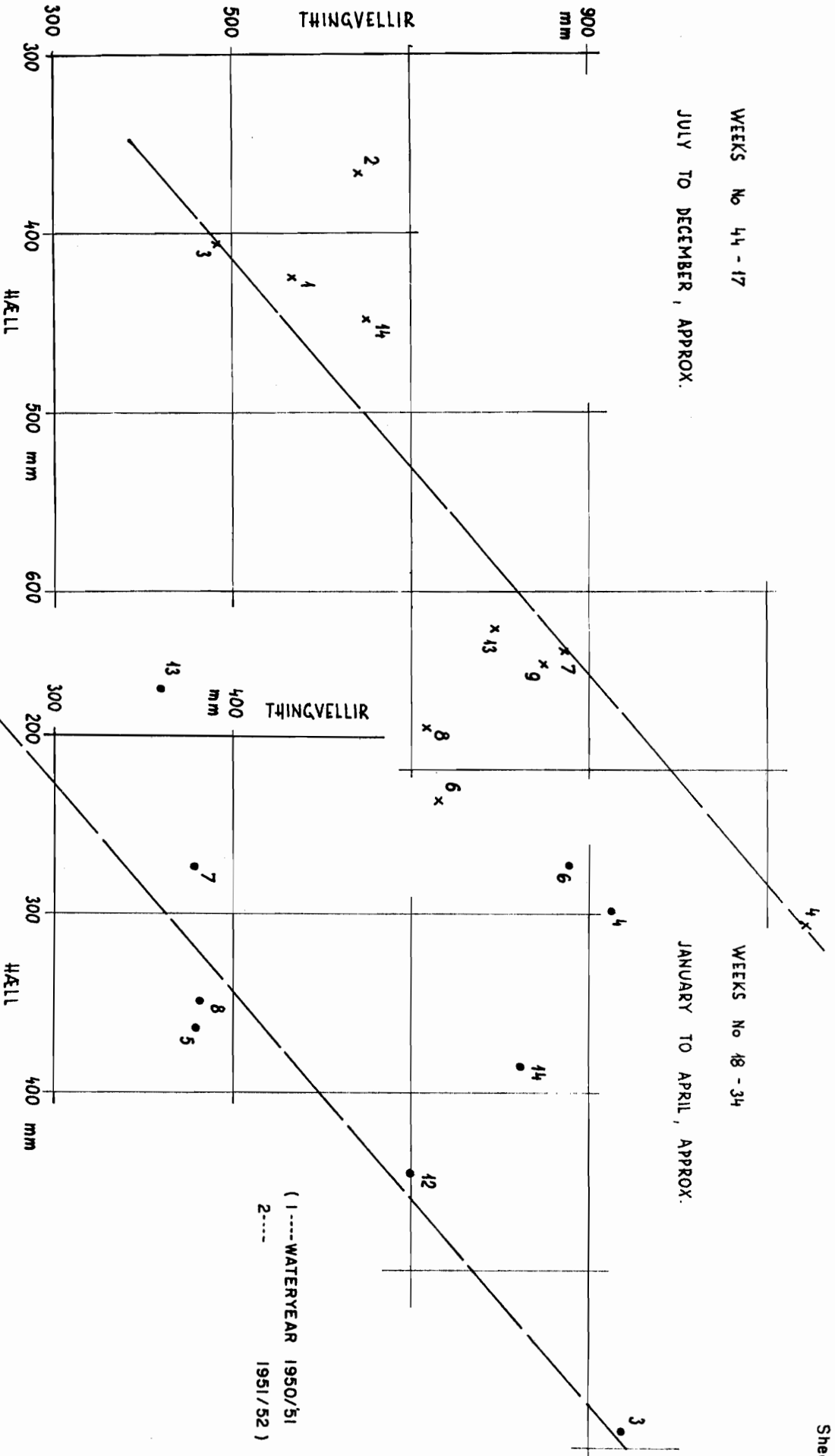

RIVER FORECASTING
THINGVELLIR/HÆLL PRECIPITATION RELATIONS
THE STATE ELECTRICITY AUTHORITY, ICELAND
UNITED NATIONS SPECIAL FUND, REYKJAVIK, ICELAND

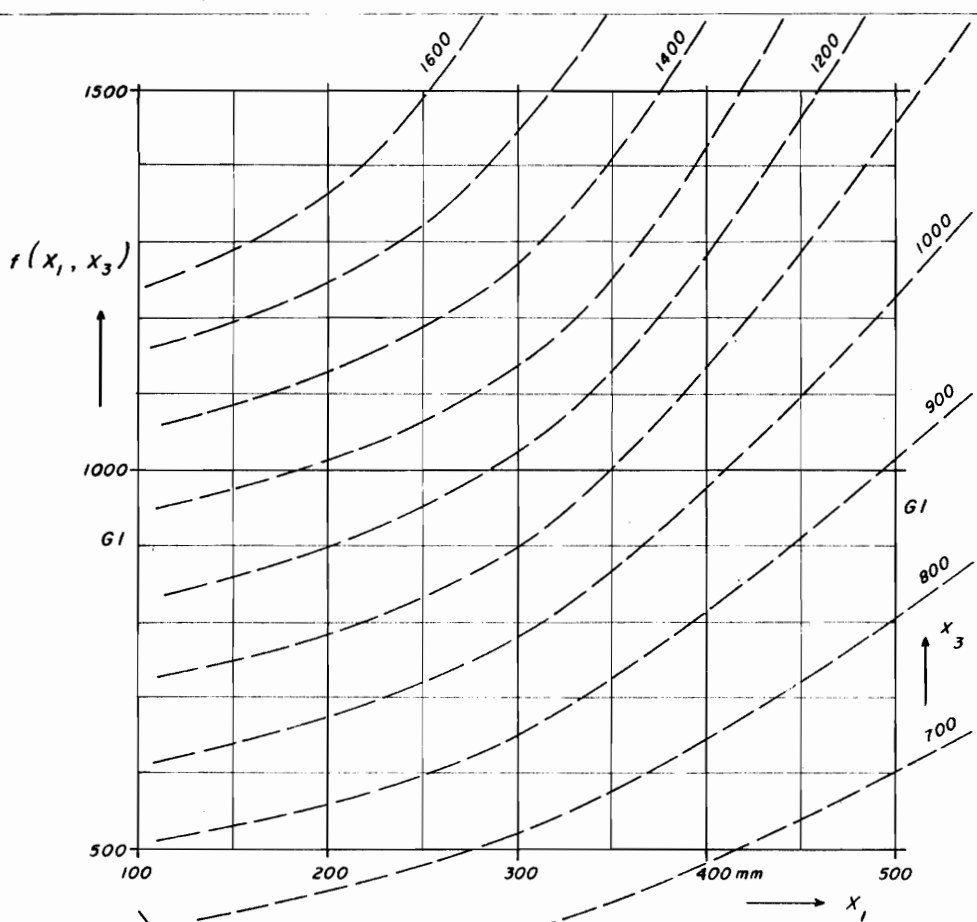

$Y = f(X_1, X_3) + (X_4) + f(X_2) + R$
 X_1 --- Precipitation at Hæll, weeks No. 5-17
 X_3 --- discharged volume at Gullfoss,
 weeks No. 44-4

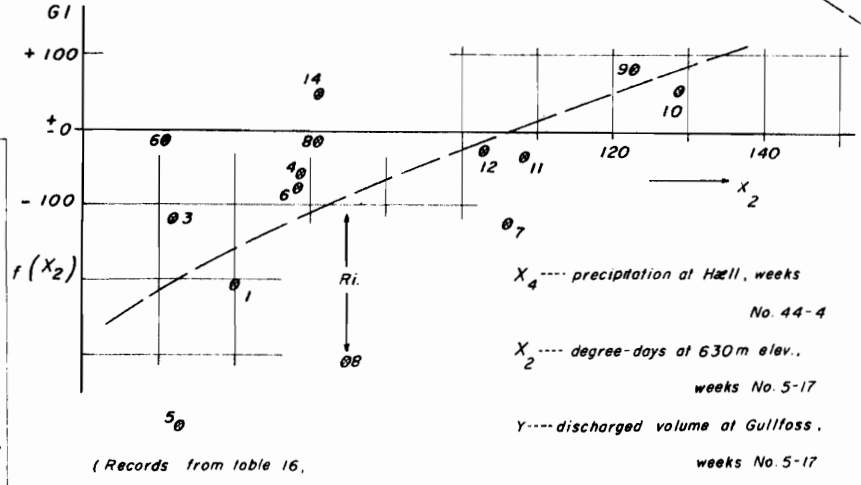
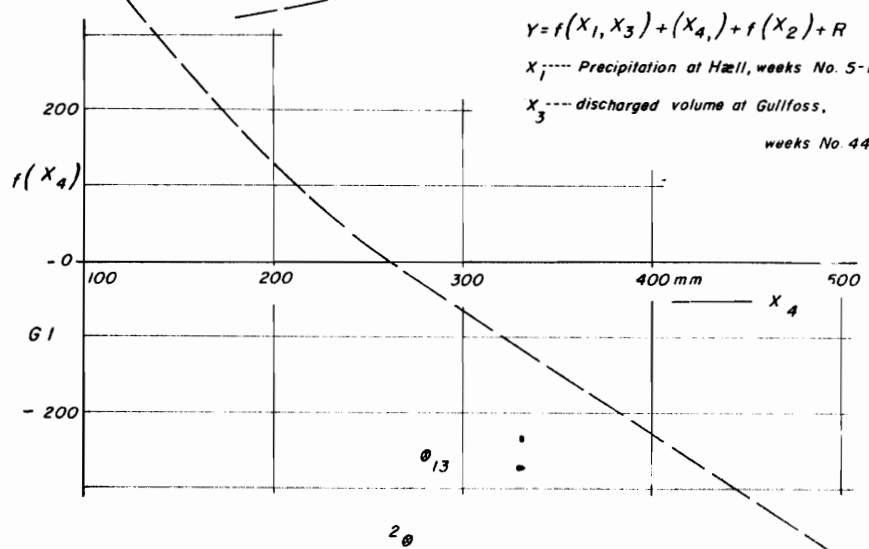

X_4 --- precipitation at Hæll, weeks
 No. 44-4
 X_2 --- degree-days at 630m elev.,
 weeks No. 5-17
 Y --- discharged volume at Gullfoss,
 weeks No. 5-17

(Records from table 16,
 A-relations)

RIVER FORECASTING - THE HVIÐA RIVER AT
 GULLFOSS - RELATION FOR DISCHARGED VOLUME
 ESTIMATION (OCT TO DEC.)
 THE STATE ELECTRICITY AUTHORITY, ICELAND
 UNITED NATIONS SPECIAL FUND, REYKJAVIK, ICELAND

Fig 18

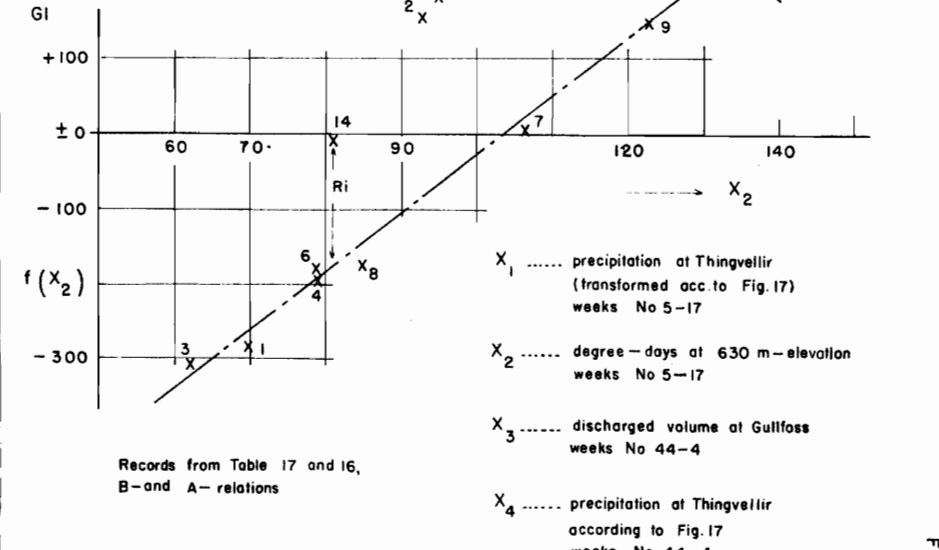
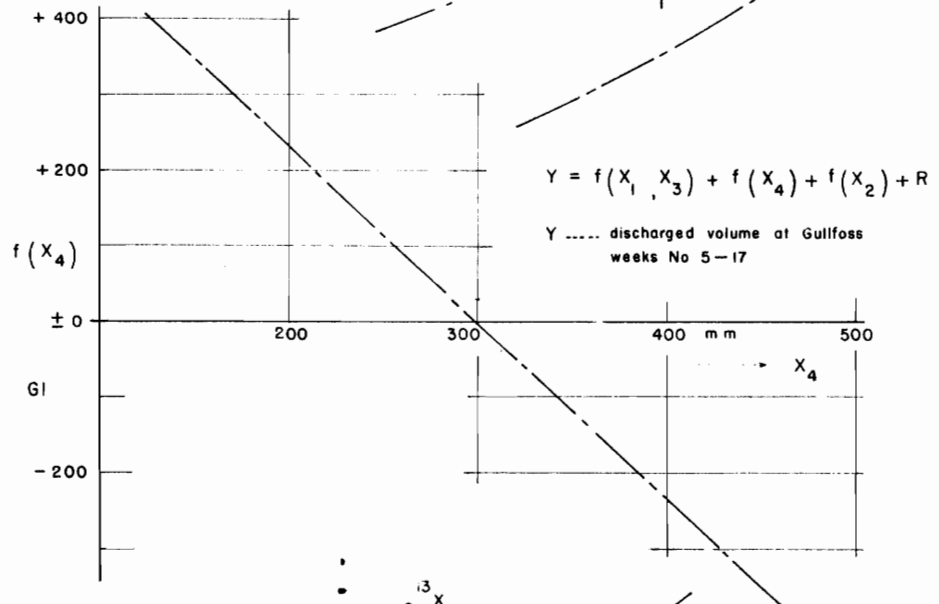
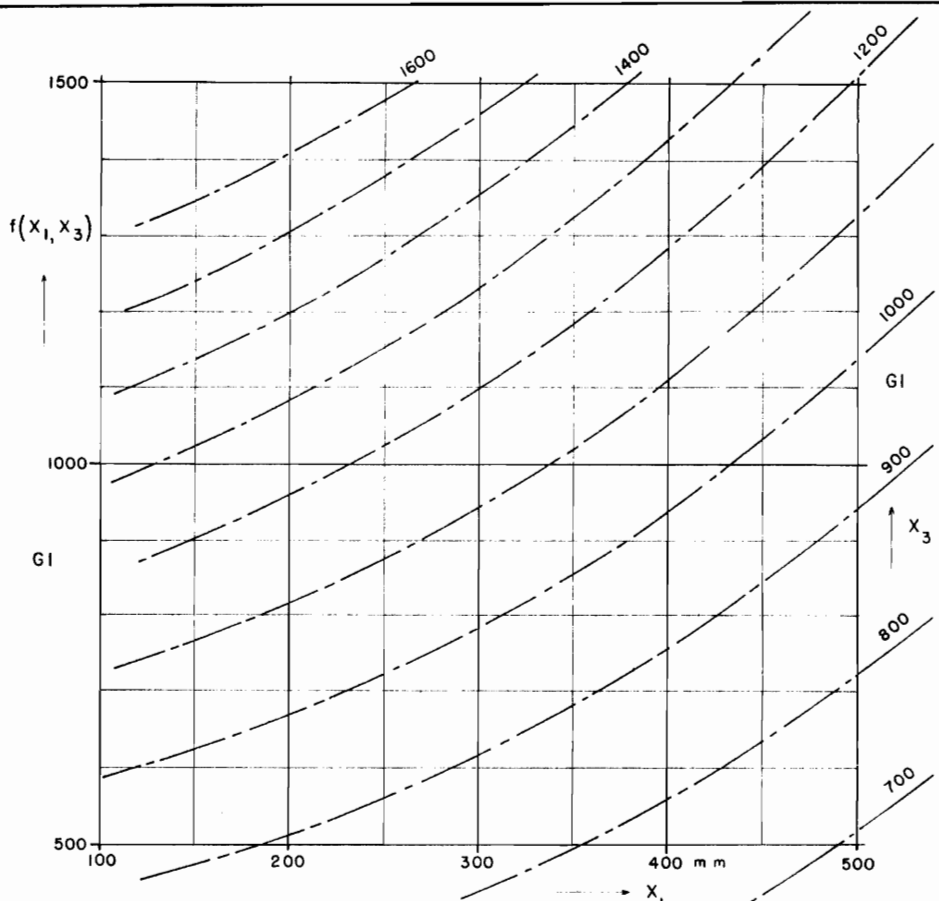

$$Y = f(X_1, X_3) + f(X_4) + f(X_2) + R$$

Y discharged volume at Gullfoss weeks No 5-17

- X_1 precipitation at Thingvellir (transformed acc.to Fig.17) weeks No 5-17
- X_2 degree-days at 630 m-elevation weeks No 5-17
- X_3 discharged volume at Gullfoss weeks No 44-4
- X_4 precipitation at Thingvellir according to Fig.17 weeks No 44-4

Records from Table 17 and 16, B- and A- relations

RIVER FORECASTING - THE HVIÐA RIVER AT GULLFOSS - RELATIONS FOR DISCHARGED VOLUME ESTIMATION (OCT. TO DEC.)
 THE STATE ELECTRICITY AUTHORITY, ICELAND
 UNITED NATIONS SPECIAL FUND, REYKJAVIK, ICELAND

Fig. 19

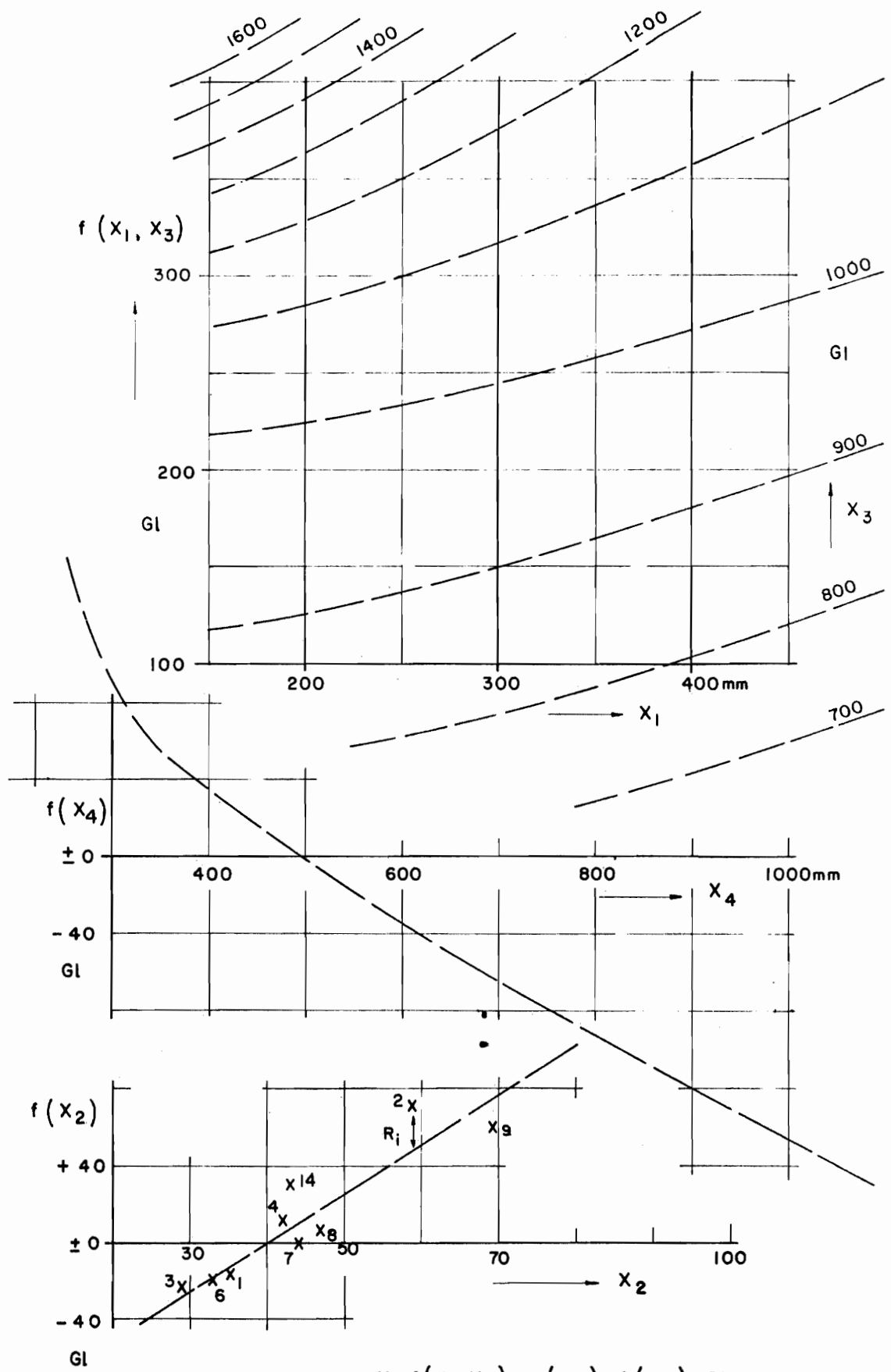

$$Y = f(x_1, x_3) + f(x_4) + f(x_2) = R$$
 SYMBOLS ACCORDING TO TABLE 18, C-RELATIONS

Fig. 20

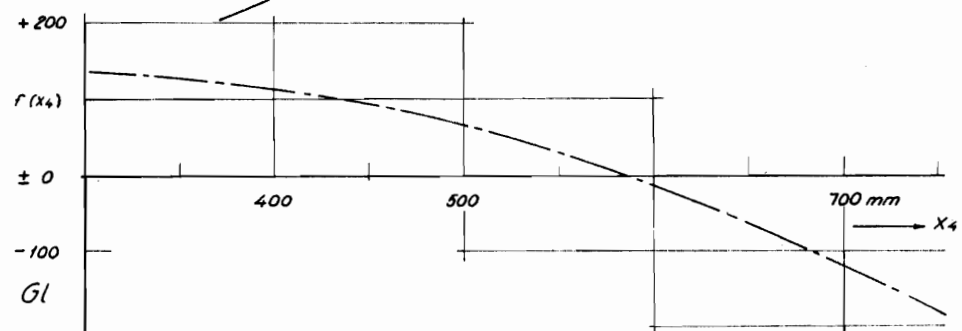
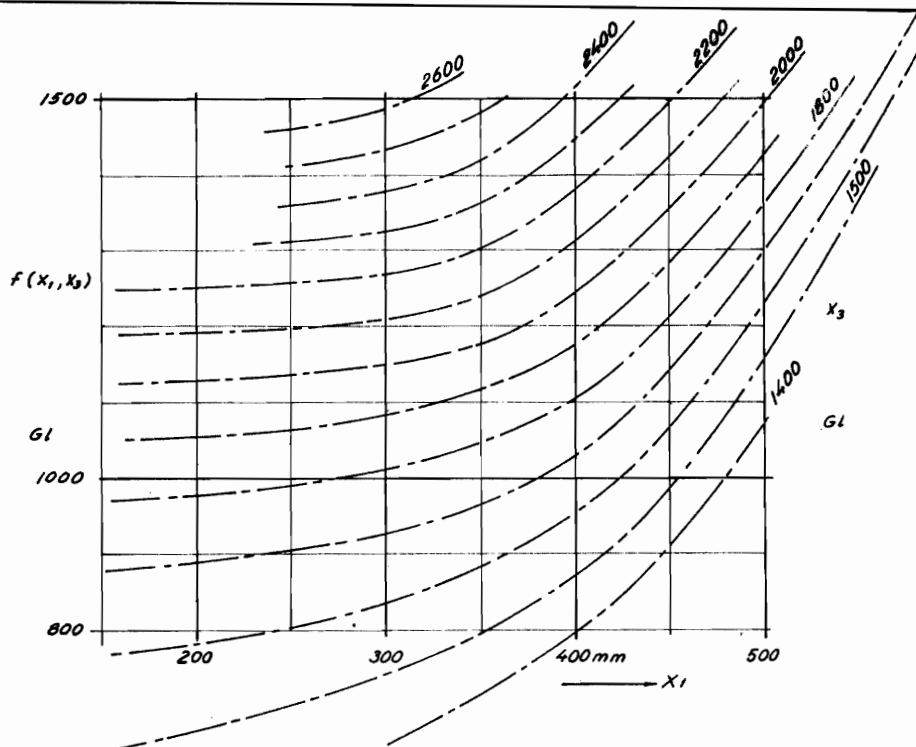

$$Y = f(x_1, x_3) + f(x_4) + f(x_2) + f(x_5) + R$$

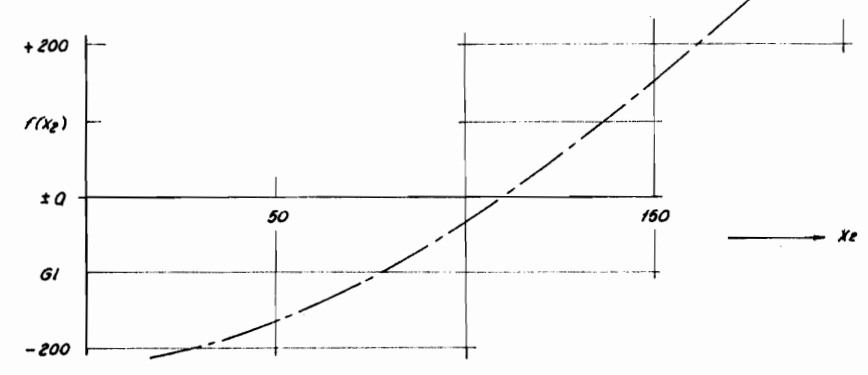

Y discharged volume at Gullfoss, weeks No 18-34
 X_1 precipitation at Haell, weeks No 18-34
 X_2 degree-days at 630 m - elevation, weeks No 18-34

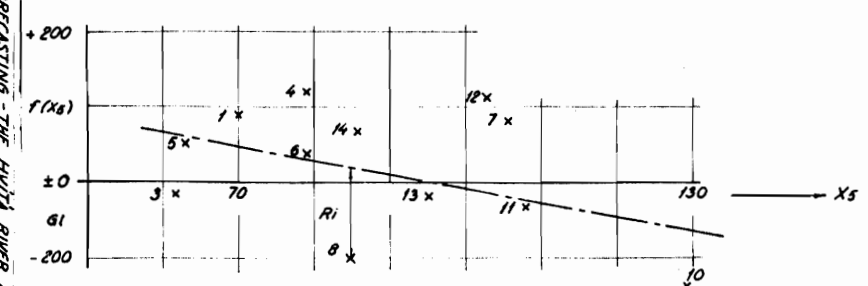

X_3 discharged volume at Gullfoss, weeks No 44-17
 X_4 precipitation at Haell, weeks No 44-17
 X_5 degree-days at 630 m - elevation, weeks No 5-17
 Records from Table 16. D - relations

RIVER FORECASTING - THE HVIPI RIVER AT GULLFOSS -
 RELATIONS FOR DISCHARGED VOLUME ESTIMATION (M.T.M.P.)
 THE STATE ELECTRICITY AUTHORITY, ICELAND
 UNITED NATIONS SPECIAL PROGRAM FOR IRELAND

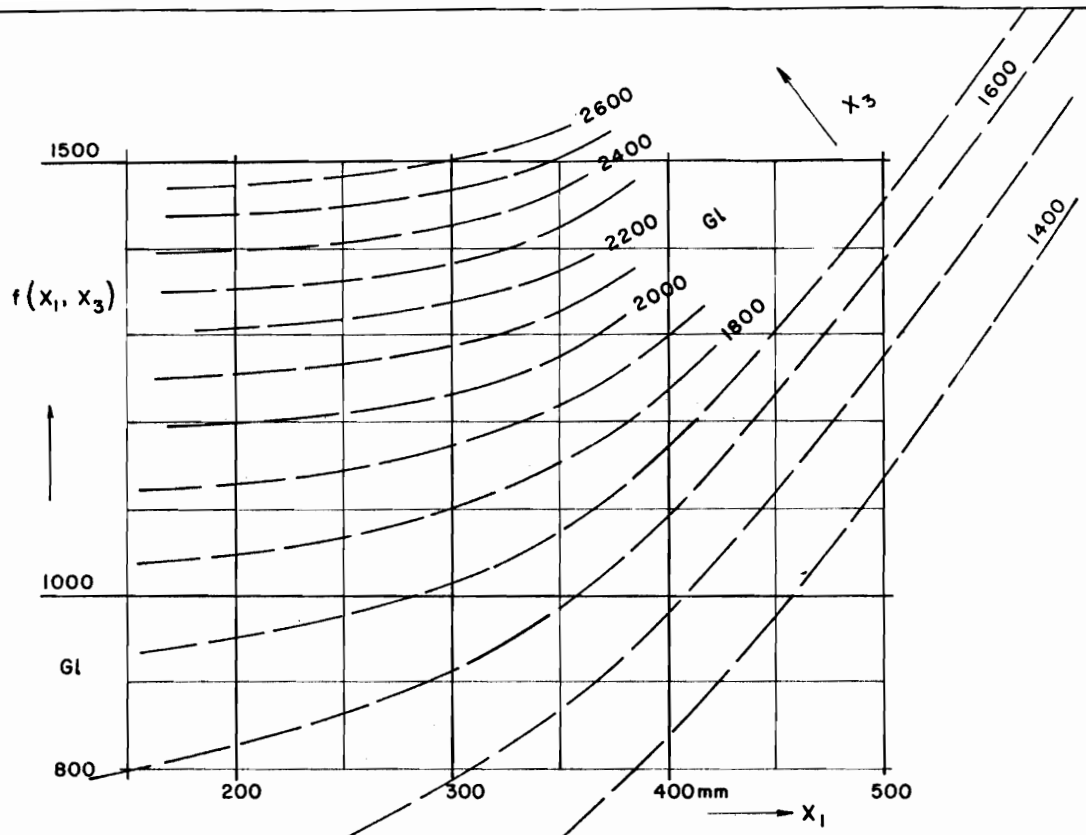

$$Y = f(X_1, X_3) + f(X_4) + R$$

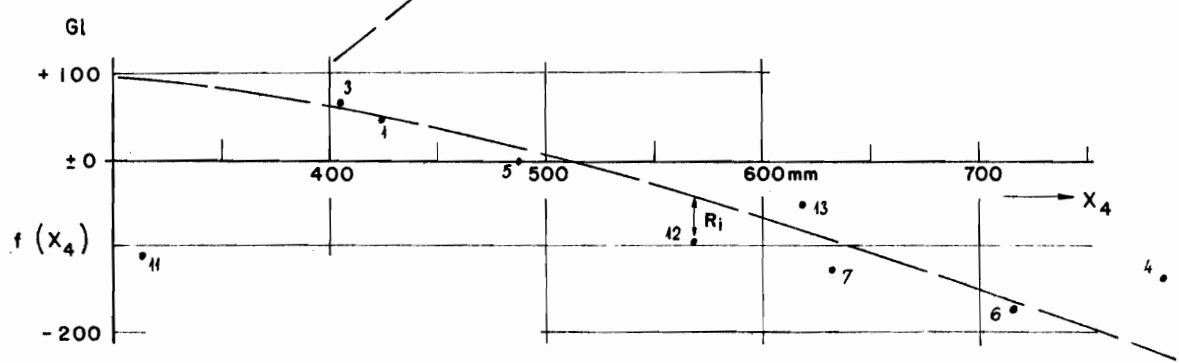

RIVER FORECASTING - THE HVIÐA RIVER AT GULLFOSS
 RELATIONS FOR DISCHARGED VOLUME FORECAST (JAN TO APR)
 THE STATE ELECTRICITY AUTHORITY, ICELAND
 UNITED NATIONS SPECIAL FUND, REYKJAVIK, ICELAND

- Restricted number of variables
- Y discharged volume at Gullfoss, weeks No. 18-34
 - X₁ precipitation at Hæll, weeks No. 18-34
 - X₃ discharged volume at Gullfoss, weeks No. 44-17
 - X₄ precipitation at Hæll, weeks No. 44-17
- (according to Table 16, D-relations)

Fig. 22

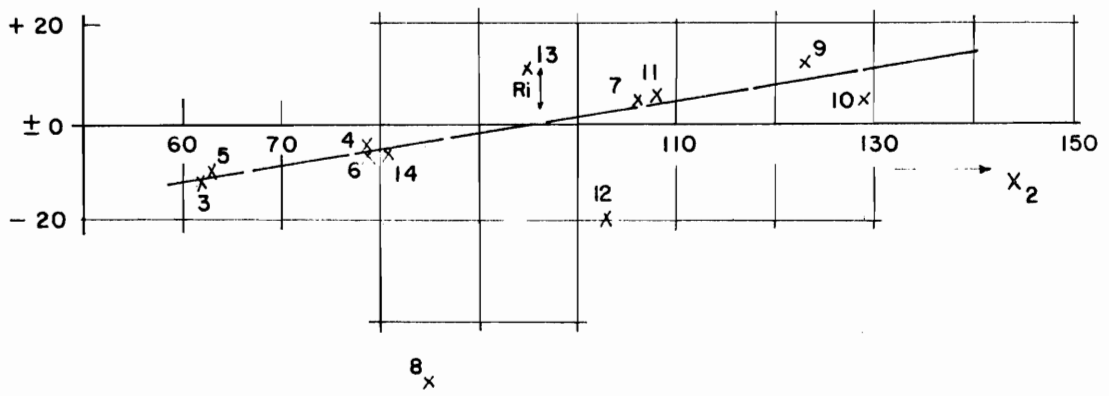
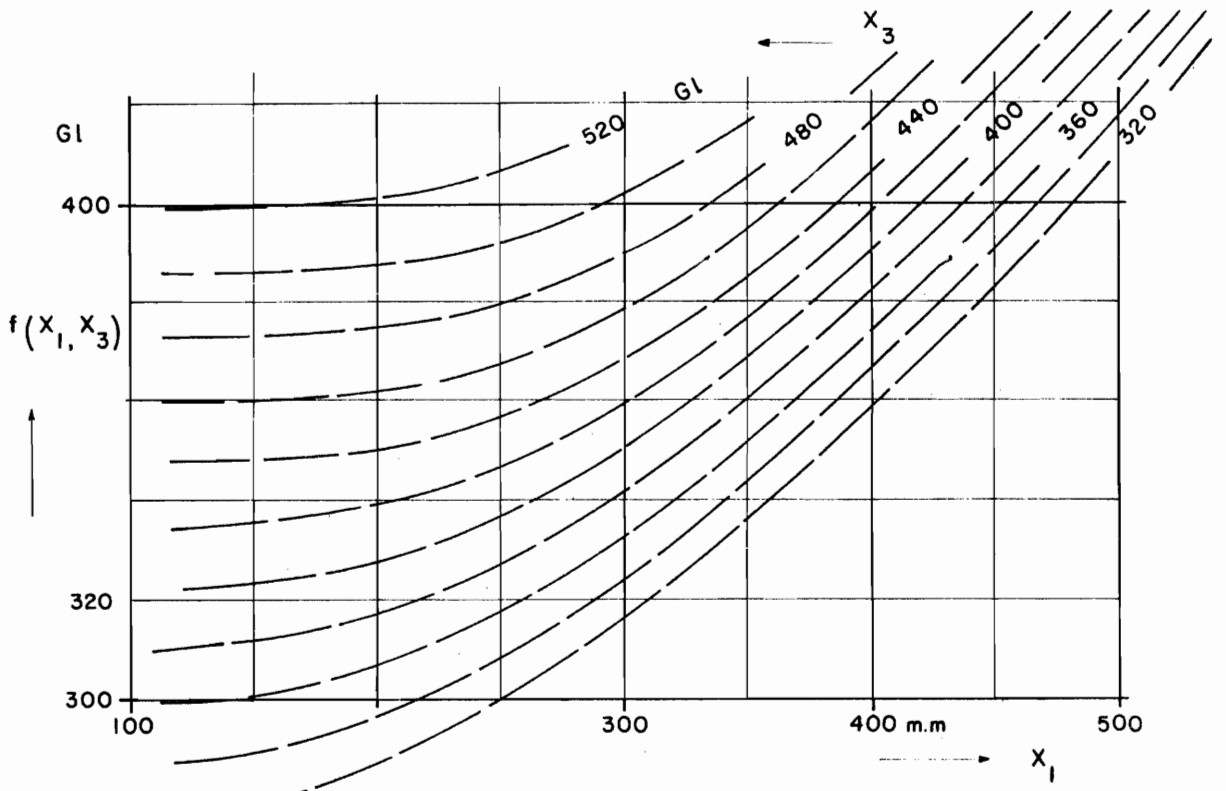

$$Y = f(X_1, X_3) + f(X_4) + f(X_2) + R$$

$$f(X_4) = 0$$

- \hat{Y} discharged volume at Faxi, weeks No 5-17
- X_1 precipitation at Hæll, weeks No 5-17
- X_2 degree-days at 630 m-elevation, weeks 5-17
- X_3 discharged volume at Faxi, weeks 44-4
- X_4 precipitation at Hæll, weeks 44-4

Records from Table 19, E_2 -relations

RIVER FORECASTING - THE TUNGFLUJÓT RIVER AT FAXI -
 RELATIONS FOR DISCHARGED VOLUME ESTIMATION (OCT. TO DEC.)
 THE STATE ELECTRICITY AUTHORITY, ICELAND
 UNITED NATIONS SPECIAL FUND, REYKJAVÍK, ICELAND

Fig. 23

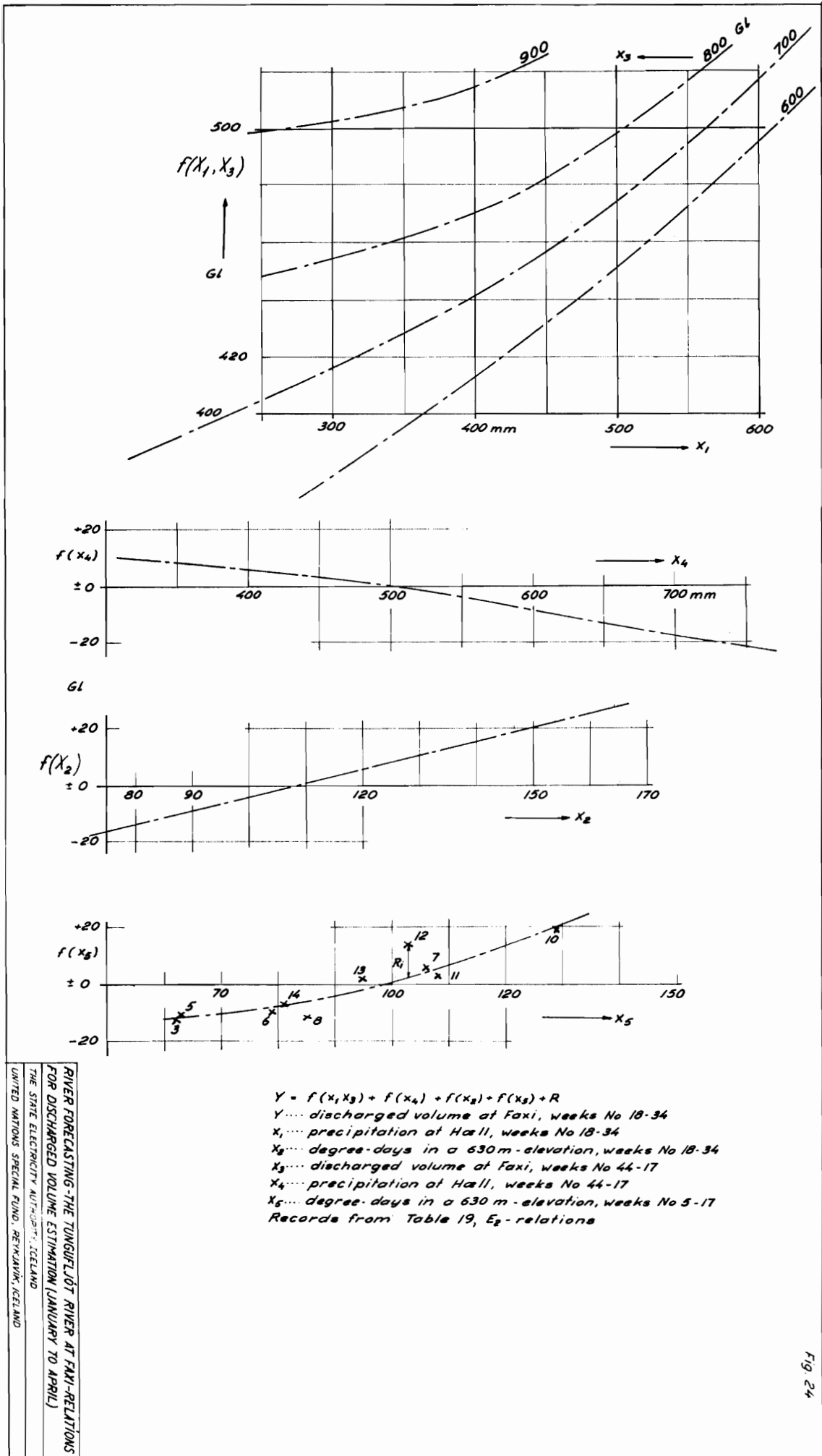

RIVER FORECASTING-THE TUNGURLOTT RIVER AT FAXI-RELATIONS
 FOR DISCHARGED VOLUME ESTIMATION (JANUARY TO APRIL)
 THE STATE ELECTRICITY AUTHORITY, ICELAND
 UNITED NATIONS SPECIAL FUND, REKJAVIK, ICELAND

Fig 24

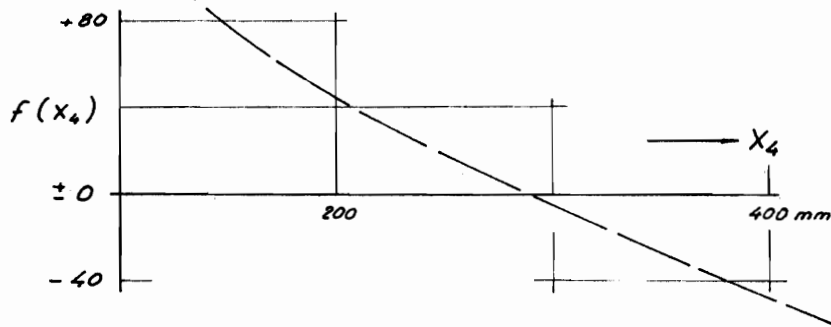
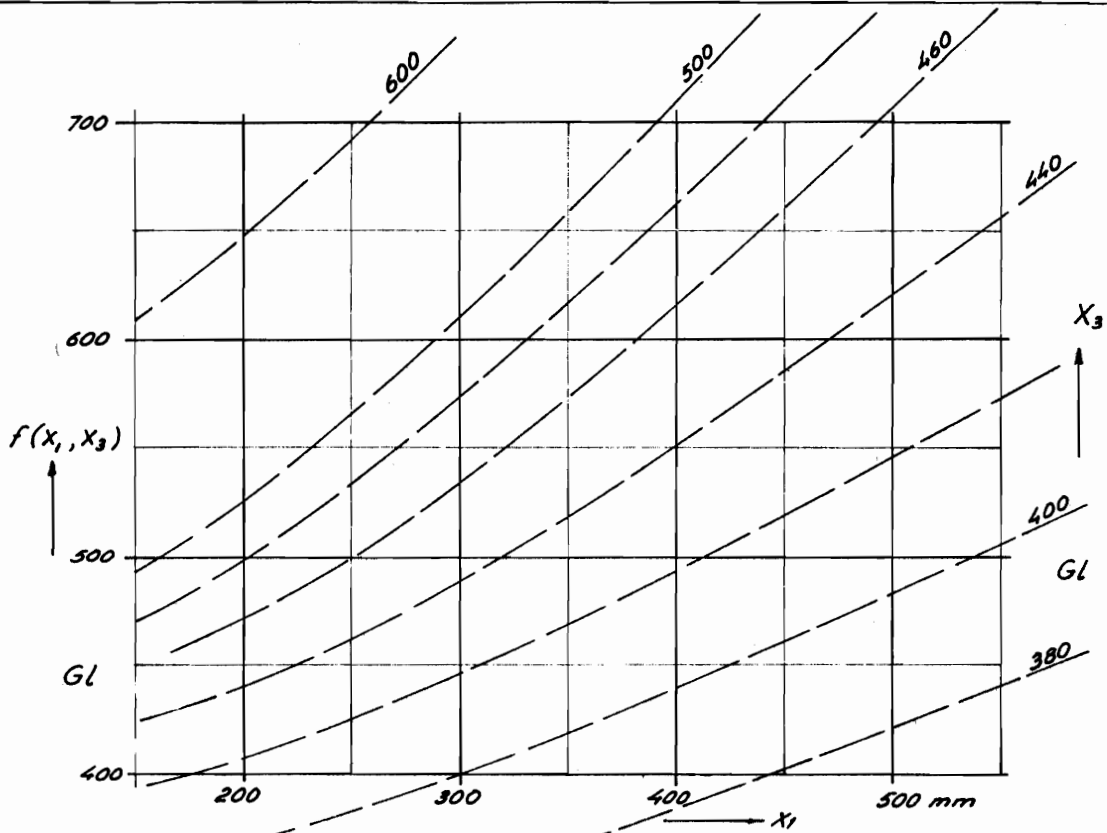

$$Gl \quad Y = f(X_1, X_3) + f(X_4) + f(X_2) + R$$

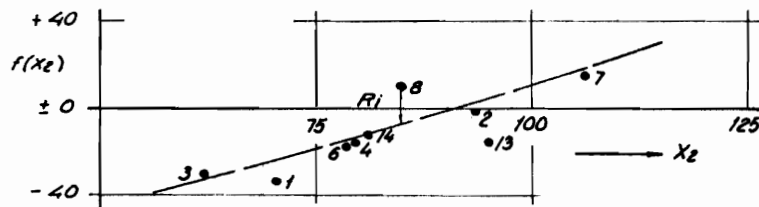

Y discharged volume of Dynjandi, weeks No 5-17
 X_1 precipitation at Thingvellir (adjusted to Haelli), weeks No 5-17
 X_2 degree-days in a 630m - elevation, weeks No 5-17
 X_3 discharged volume at Dynjandi, weeks No 44-4
 X_4 precipitation at Thingvellir (adjusted to Haelli), weeks No 44-4
 Records from Table 20, F_1 - relations, and from Table 17

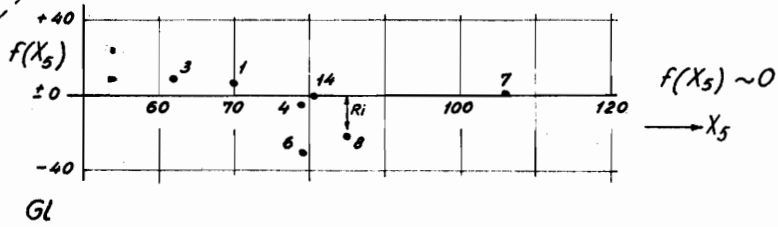
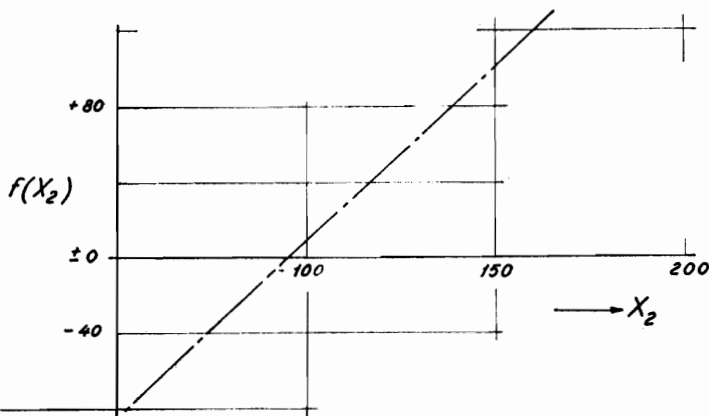
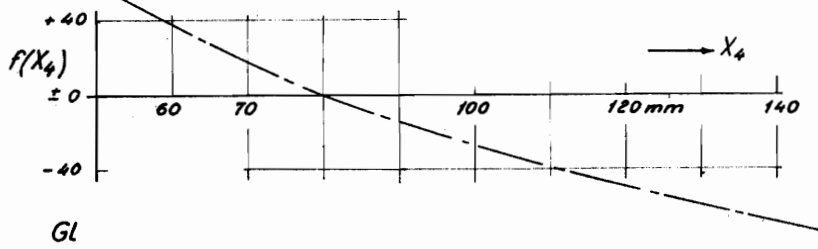
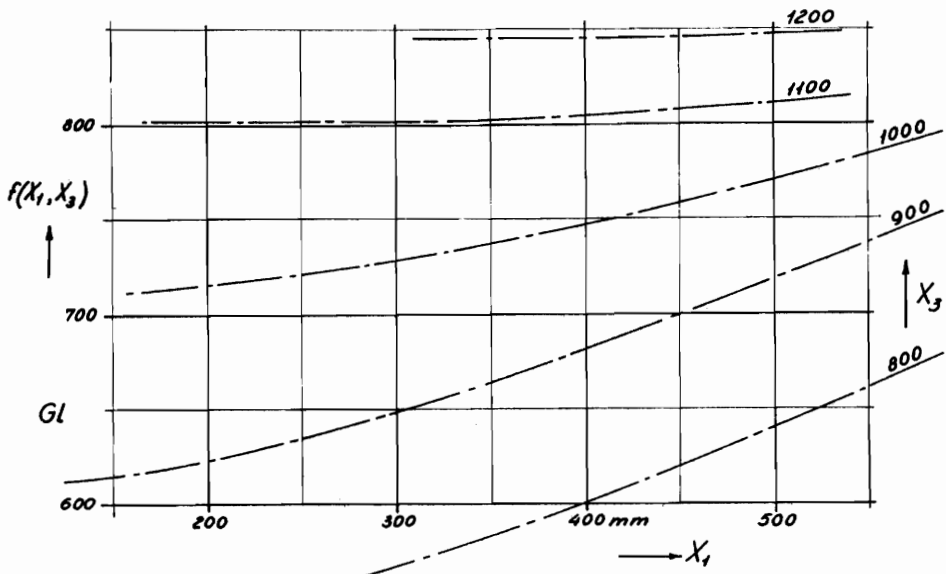

$$Y = f(X_1, X_3) + f(X_4) + f(X_2) + f(X_5) + R$$

- Y -- discharged volume at Dynjandi, weeks NO 18-34
- X_1 -- precipitation at Thingvellir (adjusted to Haall), weeks NO 18-34
- X_2 -- degree-days in a 630 m. elevation, weeks NO 18-34
- X_3 -- as Y , weeks NO 44-77
- X_4 -- as X_1 , weeks NO 44-77
- X_5 -- as X_2 , weeks NO 44-77

Records from Table 20, F_2 - relations
and from Table 17

TABLE 1

THE HVITÁ RIVER SYSTEM - CHARACTERISTIC VALUES

Name of river	Location (No of water gauge)	length from sea km	elevation above s.l. m	total drainage area km ²	drainage area part covered by glacier km ²	characteristic of river (width in m)	mean 100 years discharges m ³ /s	Remarks
1 HVITÁ (ÖLFUSÁ)	estuary	0	0	6100 M	690	L+J+S+D (1800)	395	M ... main stream
2 SOG	Selfoss (64)	18	12	5760 M	690	L+J+S+D (400)	386	1 ... tributary of first order
3	confl.w.HVITÁ	25	15	1200 1	-	L+S ¹	110	11 .. " of second order
4	below THINGVALL.	45	103	1000 1	-	L+S ¹	110	
5 HVITÁ	Árhr., Hestfj. (107)	47	48	4360 1	690	L+S+D	262	1 Lake Thingvallavatn 83 km ² , (mean 34,1 m, max 114 m) drainage area 1000 km ²
6 BRÚARÁ	confl.w.HVITÁ	56	50	707 11	-	L+S ²	70	
7 HVITÁ	Ída (41)	62	52	3540 1	690	D+L+J (500)		2 Lake Hestvatn 6 km ² , drainage area 150 km ²
8 LITLA LAXÁ	confl.w.HVITÁ	64	53	105 11	-	D+L		
9 STÓRA LAXÁ	confl.w.HVITÁ	64	53	512 11	-	D	30	
10 TUNGUFLJÓT	confl.w.HVITÁ	69	53	770 11	270	L+J	50	2 Lake Apavatn 14 km ² , drainage area 280 km ²
11 HVITÁ	Hvítárdalur	82		2090 1	420	D+J+S ² +L (90)		
12	Brúarnlöb (58)	87	85	2075 1	420	D+J+S ² +L		
13 FOSSÁ	confl.w.HVITÁ	89		30 11	-	D		
14 DALSA	confl.w.HVITÁ	89		31 11	-	D		
15 HVITÁ	Gullfoss (87)	95	189	2000 1	420	D+J+S ² +L (90) (140)	118	4 Lake Sandvatn 3 km ² , drainage area 566 km ²
16 BÚDARÁ	confl.w.HVITÁ			65 11	-	D		D .. "dragá" stream (surface runoff)
17 STANGARÁ	"			44 11	-	D		L .. "lindá" stream (underground runoff)
18 SANDÁ	"	118	320	327 11	-	D	18	J .. influence of glacier
19 GRJÓTÁ	"	125		90 11	-	D		S ... influence of lake(s)
20 HVITÁ	Ábóti (101)	129		1230 1	420	D+J+S ² (90)	77	() average width (from a few km long reach) is indicated only
21 JÓKULFALL	confl.w.HVITÁ	131	419	380 11	90	J+D		
22 HVITÁ	Hvítárbrú (57)	133	420	843 1	330	S ² +J (90)	52	5 Lake Hvítárvatn 28 km ² , depth (mean 27,6 m, max 84 m) drainage area 820 km ²
23 SVARTÁ	Hvítárvatn	137	421	133 11	-	D		

Note: design flood - upper numbers = evaluation made by Sigurjón Rist
(SEA), provided that no glacial burst will occur
- lower numbers (+) = evaluation by UN Special
Fund Project

TABLE 2

THE THJÓRSÁ RIVER SYSTEM - CHARACTERISTIC VALUES

Name of river	Location (No of water gauge)	length from sea km	elevation above s.l. m	drainage area km ²		characteristic of river (width in m)	discharges m ³ /s		Remarks
				total	part covered by glacier		mean	design flood 100 years/1000 years	
1 THJÓRSÁ	estuary	0	0	7530 M	1200	D+J+L (1500)	395		M .. main stream
2	Urrilóafoss (30)	20	21	7200 M	1200	D+J+L { (70) (900)	377	{ 5000+ 4500+	1 .. tributary of first order
3	Búðafoss	48	74	6930 M	1200	D+J+L (400)	350		11 .. " of second order
4 FOSSÁ	confl.w.THJÓRSÁ	72		223 l	-	D+L			() average width (from a
5 THJÓRSÁ	Tröllikonuhlaup			6380 M	1200	D+J+L { (200) (300)		5000	few km long reach) is
6	below TUNGNAÁ (97)	97	280	6320 M	1200	D+J+L (500)		5000	indicated only
7 TUNGNAÁ	confl.w.THJÓRSÁ	97	280	3470 l	688	L+J+D (400)	170	{ 3000+ 2500+	Lake Thórisvatn 70 km ² , depth
8 KALDAKVÍSL	confl.w.TUNGNAÁ	113	318	1740 l1	460	J+L+D	50		(mean 40,7 m, max. 110 m)
9 THÓRISÓÐ	confl.w.KALDAKV.(94)			330 l11	-	L	14	{ a+ b	a+b = 700 m ³ /s
10 KALDAKVÍSL	above Thórisóðs (95)			1120 l1	460	J+D+L	33	{ a+ b	a+b+ = 500 m ³ /s
11 TUNGNAÁ	Hrauneyjafoss	117	395	1625 l	228	L+J+D { (80) (300)	110	2000	c+d = 1500 m ³ /s
12	Vatnaöldur (96)			1350 l	228	L+J+D	95		
13 THJÓRSÁ	Dynkur			2615 M	512	D+J (200)		{ 3500+ 2500+	D... "dragá" stream (surface
14 DALSA	confl.w.THJÓRSÁ	127	500	253 l	-	D+S			runoff)
15 KISA	confl.w.THJÓRSÁ	131	510	147 l	-	D			L .. "lindá" stream (under-
16 THJÓRSÁ	Norðlingaalda (100)			2060 M	512	D+J (180)	100	{ 3000+ 2000+	ground runoff)
17	Sóleyjarnhöfði	155	580	1740 M	480	J+D			J .. influence of glacier
									S .. influence of lake(s)

Note: design flood: upper numbers = evaluation made by Sigurjón Rist
(State Electricity Authority, Reykjavík) provided that
no glacial burst will occur
lower numbers (+) = evaluation used in the
UN Special Fund Project

TABLE 3

THE HVITÁ RIVER
GULLFOSS STATION

water year	DISCHARGED VOLUMES in Gl (mill. m ³) (PERIODS IN MONTHS)									
	7	7-8	7-9	7-10	7-11	7-12	7-1	7-2	7-3	7-4
1 50/51	303	692	897	1069	1243	1463	1599	1724	1848	1988
2 51/52	293	522	732	1025	1213	1546	1653	1931	2139	2395
3 52/53	416	785	1033	1278	1463	1635	1849	2083	3112	3408
4 53/54	429	816	1169	1547	1944	2593	3078	3297	3592	3960
5 54/55	441	779	1034	1261	1475	1645	1840	1933	2110	2690
6 55/56	542	1148	1555	1810	2079	2283	2575	2888	3162	3478
7 56/57	337	579	795	1092	1597	1841	2135	2339	2514	2820
8 57/58	370	718	942	1245	1486	1789	1986	2129	2272	2579

TABLE 4

THE HVÍTÁ RIVER
GULLFOSS STATION

WATER YEAR	DISCHARGED VOLUMES in G1 (mill. m ³) (PERIODS IN MONTHS)									
	7-4	8-4	9-4	10-4	11-4	12-4	1-4	2-4	3-4	4
1	1988	1685	1296	1091	919	745	525	389	264	140
2	2395	2102	1873	1663	1370	1182	849	742	464	256
3	3408	2992	2623	2375	2130	1945	1773	1559	1325	296
4	3960	3531	3144	2791	2413	2016	1367	882	663	368
5	2689	2248	1910	1655	1428	1214	1044	850	757	580
6	3476	2934	2328	1921	1666	1397	1193	901	590	316
7	2820	2483	2241	2025	1728	1223	979	685	481	306
8	2579	2209	1861	1637	1334	1093	790	593	450	307

THE HVÍTA RIVER
GULLFOSS STATION

Actual deviations from the guaranteed discharged
volume forecasts issued on

water year	September 30			October 31			December 31			February 28		
	G1	G1	%	G1	G1	%	G1	G1	%	G1	G1	%
1	1090	1091	0	920	919	0	520	525	0	260	264	0
2	900	1663	43	870	1370	30	590	849	16	320	464	9
3	1250	2375	47	1140	2130	29	630	1773	48	360	1325	36
4	1430	2791	49	1410	2413	36	1380	1367	0	670	663	0
5	1250	1655	24	1120	1428	20	660	1044	23	320	757	26
6	1920	1921	-	1670	1666	0	1130	1193	3	560	590	2
7	960	2025	52	940	1728	39	800	979	9	420	481	3
8	1140	1637	30	1100	1334	14	760	790	2	370	450	4
	a	b	c	d	e	f	g	h	k	l	m	n

a, d, g, l ... forecasted values (till end of April)

b, e, h, m ... actual values (till end of April)

$$c = \frac{b-a}{b} \quad 100\%$$

$$k = \frac{h-g}{g} \quad 100\%$$

$$f = \frac{e-d}{d} \quad 100\%$$

$$n = \frac{m-l}{l} \quad 100\%$$

THE HVÍTÁ RIVER
GULLFOSS STATION

Test of the forecasting method developed on base
of discharged volumes during the 8 wateryears'
period (till 1957/58)

water year	discharged volume in G1 (weeks No 44 to 4, incl.) July to Sept. approx.	weeks No 5 to 34, incl. (Oct. to April, approx.) discharged volume in G1		deviation (in per cent)	
		forecasted minimum	actual value	above the forecast. minimum	round the most expected value (37%)
9 58/59	934	1140	2485	54	+17
10 59/60	1290	1600	2250	29	- 8
11 60/61	983	1180	1640	28	- 9
12 61/62	860	1040	1683	38	+ 1
13 62/63	869	1050	1908	45	+ 8
14 63/64	839	1010	2010	50	+13

TABLE 7

The Tungufljót River
Faxi Station

WATER YEAR	DISCHARGED VOLUMES IN G1 (PERIODS IN WATERYEARS WEEKS)				
	44-04	44-08	44-12	44-17	44-25
3 52/53	364	456	547	656	870
4	403	531	643	833	1083
5	420	530	646	773	963
6	513	648	772	903	1123
7	375	506	665	817	1036
8	394	517	621	767	952
9	364	483	625	772	909
10	419	565	678	806	1042
11	408	518	620	742	961
12	356	464	566	679	878
13	339	452	553	698	881
14	332	423	510	633	871

TABLE 8

The Tungufljót River
Faxi Station

WATER YEAR	DISCHARGED VOLUMES IN G1 (PERIODS IN WATERYEAR'S WEEKS)				
	5-34	9-34	13-34	18-34	26-34
3 52/53	797	705	614	505	291
4	935	807	695	505	355
5	796	686	570	443	253
6	860	725	601	470	250
7	881	750	591	439	220
8	781	658	554	408	223
9	891	772	630	483	246
10	863	717	604	476	240
11	802	692	590	468	249
12	766	658	556	443	244
13	747	634	533	388	205
14	741	650	563	440	202

TABLE 9

The Tungufljót River - Faxi Station

Part (%) of total runoff volume (in the period from 5th through 34th week of the wateryear) that is not covered with the guaranteed-volume-forecast

water-year	the moment of the forecast (the end of the week No "x")										
	4			8		12		17		25	
	G1	G1	%	G1	%	G1	%	G1	%	G1	%
3 52/53	37	797	5	x)	x)	x)					
4	150	935	16	140	15	135	14	85	9		
5	5	796	1								
6	0	860	0								
7	115	881	13	95	11	20	2	20	2	0	0
8	2	781	0	0	0						
9	130	891	15	130	15	75	8	70	8	40	4
10	70	863	8	30	3	30	3			20	2
11	15	802	2								
12	10	766	1								
13	5	747	1			0	0	0	0		
14	0	741	0							0	0
	a	b	c	a	c	a	c	a	c	a	c

x) no value is indicated if higher than in the antecedent moment of the forecast

a = ACTUAL VALUE MINUS THE FORECASTED ONE

b = DISCHARGED WATER VOLUME (FROM 5th THROUGH 34th WEEK OF THE WATERYEAR)

c = $(a:b) \cdot 100\%$

TABLE 10

Brúará River
Dynjandi Station

DISCHARGED VOLUMES IN G1 (PERIODS IN MONTHS)

WATER YEAR	7	7-8	7-9	7-10	7-11	7-12	7-1	7-2	7-3	7-4
0 49/50	206	391	587	790	963	1143	1370	1525	1688	1830
1	146	291	433	579	730	905	1078	1213	1376	1526
2	141	274	403	574	721	899	1074	1261	1449	1645
3	157	299	435	580	725	866	1020	1196	1554	1731
4	157	302	462	670	897	1214	1459	1649	1849	2048
5	155	303	445	604	783	940	1123	1283	1445	1643
6	211	424	634	832	1013	1183	1397	1599	1794	1969
7	147	286	420	604	843	1051	1269	1434	1588	1764
8	145	289	423	602	795	988	1143	1280	1435	1618

Brúará River
Dynjandi Station

WATER YEAR	DISCHARGED VOLUMES in G1 (PERIODS IN MONTHS)									
	7-4	8-4	9-4	10-4	11-4	12-4	1-4	2-4	3-4	4
0	1830	1624	1439	1243	1040	867	687	460	305	142
1	1526	1380	1235	1093	947	796	621	448	313	150
2	1655	1514	1381	1252	1081	934	756	581	394	196
3	1731	1574	1432	1296	1151	1006	865	711	535	177
4	2045	1888	1743	1583	1375	1148	831	589	399	199
5	1643	1488	1340	1198	1039	860	703	520	360	198
6	1969	1758	1545	1335	1137	956	786	572	370	175
7	1764	1617	1478	1344	1160	921	713	495	330	176
8	1620	1475	1331	1197	1018	825	632	475	338	183

BRÚARÁ RIVER

DYNJANDI STATION

Forecast of the guaranteed volume
of discharge (through the perbd
Sept.-April, incl.) issued on

year	Sept. 30			Oct. 31			Dec. 31			Febr. 28		
	G1	actually Oct-Apr. G1	%	G1	act. G1	%	G1	actual. G1	%	G1	actually G1	%
0 49/50	1250	1243	-	1040	1040	-	680	687	-	310	305	-
1	1090	1093	-	950	947	-	600	621	2	300	313	1
2	1070	1252	15	940	1080	11	600	756	x)	300	394	7
3	1090	1296	15	950	1150	15	590	865	x)	290	535	x)
4	1120	1583	29	990	1375	24	710	831	8	310	399	6
5	1110	1198	7	960	1039	7	610	703	x)	300	360	5
6	1290	1335	3	1060	1137	x)	700	786	x)	310	370	4
7	1080	1344	20	960	1160	7	650	713	5	300	330	2
8	1080	1197	10	960	1018	5	630	632	-	300	338	3
	a	b	c	d	e	f	g	h	k	l	m	n

a, d, g, l, .. forecasted min. values (till end of April)

b, e, h, m, .. actual values (till end of April)

$$c = \frac{b-a}{b} \quad 100\%$$

$$k = \frac{h-g}{b} \quad 100\%$$

$$f = \frac{e-d}{b} \quad 100\%$$

$$n = \frac{m-l}{b} \quad 100\%$$

x) no value is indicated if higher than in the antecedent moment of forecasting

THE BRÚARÁ RIVER
DYNJANDI STATION

Test of the guaranteed discharged volume forecast.
The forecast method was carried out on the base of
the first nine years' period of hydrological observa-
tion (till 1957/58)

water year	weeks No 44 to 4, incl. - (July to Sept. approx.) - discharged volume in G1	weeks No 5 to 34, incl. (Oct to April approx.) discharged volume in G1		deviation (in per cent)	
		forecasted mimimum	actual value	above the forecasted minimum	round the most expected value (10%)
1958/59	393	1060	1416	25	+15
59/60	494	1160	1363	15	+ 5
60/61	450	1110	1211	8	- 2
61/62	420	1080	1109	3	- 7
62/63	391	1060	1076	1	- 9
63/64	378	1040	1035	0	-10

TRANSFORMATION OF DEGREE-DAYS FROM EL.130 (Haell station)
TO EL.630 m (MEAN EL. OF THE HVÍTÁ RIVER BASIN ABOVE
GULLFOSS* CROSS-SECTION)

$$\Delta H = 500 \text{ m}$$

month	estimated temperature gradient Δt ($^{\circ}\text{C}/100\text{m}$)	resulting temperature differences $^{\circ}\text{C}$	transformation coefficient "a" (from FIG. 15 and for equation mentioned there)
July	0,8	4,0	0,67
August	0,8	4,0	0,62
Sept.	0,8	4,0	0,50
Oct.	0,7	3,5	0,42
Nov.	0,6	3,0	0,36
Dec.	0,5	2,5	0,33
Jan.	0,5	2,5	0,33
Febr.	0,4	2,0	0,35
March	0,5	2,5	0,38
April	0,6	3,0	0,40
May	0,6	3,0	
June	0,7	3,5	

DEGREE-DAY VALUES ABOVE 0° , $+2^{\circ}$, $+4^{\circ}$ AND 6°C
 (provided that $D-D_{t>0} = 1,00 = 100\%$)

14 years' records (1950/51 till 1963/64)

MONTH	D-D				MET.STATION
	$t > 0$	$t > 2^{\circ}$	$t > 4^{\circ}$	$t > 6^{\circ}\text{C}$	
July	100	86	67	49	Hael Thingvellir
	100		69		
August	100	79	62	44	Hael Thingv.
	100		62		
Sept.	100	72	50	29	Hael Thingv.
	100		50		
Oct.	100	64	34	14	H. Th.
	100		32		
Nov.	100	54	24	6	H. Th.
	100		24		
Dec.	100	42	14	2	H. Th.
	100		14		
Jan.	100	48	13	3	H. Th.
	100		10		
Febr.	100	35	9	1	H. Th.
	100		8		
March	100	47	16	2	H. Th.
	100		16		
April	100	57	25	7	H. Th.
	100		21		

RUNOFF in G1 (WATER GAUGE No 87 - GULLFOSS, HVÍTA RIVER)

PRECIPITATION in mm (Meteorological station HÆLL)

DEGREE-DAYS in °C-DAY (from HÆLL, adjusted to an average elevation of the Gullfoss' catchment area: 630 m)

WATER YEAR	PERIOD IN WATERYEAR'S WEEKS (BEGIN. ON SEPT. 1)											
	44-4			5-17			44-17			18-34		
	D-D	PR.	RUN	D-D	PR.	RUN	D-D	PR.	RUN	D-D	PR.	RUN
50/ 51=1	570	178	897	70	247	566	425	1463	20	165	525	
2	585	149	732	93	217	814	366	1546	(80)		849	
3	545	243	1033	62	163	602	406	1635	127	590	1773	
4	622	300	1169	79	486	1424	786	2593	107	298	1367	
5	523	178	1034	63	310	611	488	1645	102	364	1044	
6	484	555	1555	79	162	728	717	2283	106	272	1193	
7	550	119	795	106	514	1046	633	1841	81	273	979	
8	563	202	942	85	473	847	676	1789	74	349	790	
9	532	200	934	123	440	1159	640	2083			1336	
10	543	401	1290	129	360	1090	761	2380	130	380	1160	
11	604	193	983	108	121	582	314	1565	90	445	1058	
12	552	240	860	103	329	656	569	1516	78	445	1027	
13	514	262	869	95	358	921	620	1790	126	174	987	
14	496	188	839	81	260	731	448	1570	162	385	1279	

x_4	x_3	x_2	x_1	y
-------	-------	-------	-------	-----

A-RELATIONS

D-RELATIONS =

x_5

x_4	x_3	x_2	x_1	y
-------	-------	-------	-------	-----

PRECIPITATION in mm (at Thingvellir)

Water year	PERIOD IN WATERYEAR'S WEEKS (BEGINNING FROM SEPT. 1)			
	44-4 PREC.	5-17 PREC.	44-17 PREC.	18-34 PREC.
1 50/51	200	367	567	220
2	146	495	641	
3	221	262	483	618
4	370	774	1144	612
5		430		379
6	496	234	730	588
7	140	733	873	378
8	162	555	717	381
9	213	635	848	545
10				
11	164			
12		328		499
13	314	480	794	359
14	264	387	651	561

$x_4 \dots\dots\dots x_1 \dots \equiv$ B-RELATIONS

$x_4 \dots\dots\dots x_1$

RUNOFF in G1 (WATERGAUGE No 87 - GULLFOSS, HVÍTÁ RIVER)

PRECIPITATION in mm (sum of the records at Haell and Thingv.)

WATER
YEAR

DEGREE-DAYS in °C-day (from HÆLL, adjusted to an average

elevation of the Hvítá river basin above Gullfoss: 600 m)

		PERIOD EXPRESSED IN WEEKS OF THE WATERYEAR (BEGINNING FROM SEPT:1)										
		44-4		5-8			9-12			13-17		
		PREC. RUNOFF		D-D PREC. RUNOFF			D-D PREC. RUNOFF			D-D PREC. RUNOFF		
50/ 51 ≡												
≡ 1		378	897	35	187	146	25	207	163	10	220	252
2		295	732	59	365	228	24	114	243	10	233	338
3		464	1033	29	173	228	22	183	177	21	69	116
4		670	1169	42	353	343	19	299	300	18	608	764
5			1034	30	239	211	17	319	178	16	182	223
6		1051	1555	33	176	234	38	141	220	8	79	253
7		259	795	44	375	230	48	535	508	14	337	297
8		365	942	47	410	272	20	210	189	18	408	382
9		413	934	69	257	250	34	588	467	20	230	432
10			1290	93		448	16		339	20		303
11		357	983	60		205	36		174	12		203
12			860	67	209	228	22	355	216	14	93	212
13		576	869	63	275	317	16	185	246	16	378	358
14		452	839	43	237	189	16	56	225	22	354	317

x_4	x_3	x_2	x_1	Y	= C-RELATIONS
-------	-------	-------	-------	-----	---------------

TABLE 19

RUNOFF in G1 (WATERGAUGE No 68 - FAXI, TUNGUFLJÓT RIVER)
 PRECIPITATION in mm (meteorological station HÆLL)
 DEGREE-DAYS in °C-day (from HÆLL, adjusted to an average
 elevation of the catchment area: 630 m)

PERIOD IN WATERYEARS WEEKS (BEGINNING ON SEPT. 1)

	44-4		5-17			44-17		18-34		
	PREC. RUNOFF		D-D PREC. RUNOFF			PREC. RUNOFF		D-D PREC. RUNOFF		
50/51 ≡										
≡ 1										
2										
3	243	364	62	163	292	406	656	127	590	505
4	300	403	79	486	430	786	833	107	298	205
5	178	420	63	310	353	488	773	102	364	443
6	555	513	79	162	390	717	903	106	272	470
7	119	375	106	514	442	633	817	81	273	439
8	203	394	85	473	373	676	767	74	349	408
9	200	364	123	440	408	640	772			483
10	401	419	129	360	387	761	806	130	380	476
11	193	408	108	121	334	314	742	90	445	468
12	240	356	103	329	323	569	679	78	445	443
13	262	339	95	358	359	620	698	126	174	388
14	188	332	81	260	301	448	633	162	385	440

$X_4 \quad X_3 \quad X_2 \quad X_1 \quad Y \quad \equiv \quad E_1 - \text{RELATIONS}$

$E_2 - \text{RELATIONS} \equiv \quad X_5$

$X_4 \quad X_3 \quad X_2 \quad X_1 \quad Y$

RUNOFF IN G1 (WATERGAUGE No 43 - DYNJANDI, BRÚARÁ RIVER)
 PRECIPITATION in mm (meteorological station Haell)
 DEGREE-DAYS in °C-day (from Haell, adjusted to an average
 elevation of the drainage area: 630 m)

WATER
YEAR

		PERIOD IN WATERYEAR'S WEEKS (BEGINNING ON SEPT. 1)									
		44-4		5-17			44-17		18-34		
		PREC. RUNOFF		D-D PREC. RUNOFF			PREC. RUNOFF		D-D PREC. RUNOFF		
50/51											
≡1		178	433	70	247	472	425	905	20	165	621
2		149	403	93	217	496	366	399			756
3		243	435	62	163	431	406	866	127	590	865
4		300	462	79	486	752	786	1214	107	298	831
5		178	445	63	310	495	488	940	102	364	703
6		555	634	79	162	549	717	1183	106	272	786
7		119	420	106	514	631	633	1051	81	273	713
8		203	423	85	473	565	678	988	74	349	632
9		200	393	123	440	612	640	1005			804
10		401	494	129	360	605	761	1099	130	380	758
11		193	450	108	121	441	314	891	90	445	770
12		240	420	103	329	402	569	822	78	445	707
13		262	391	95	358	389	620	780	126	174	687
14		188	378	81	260	376	488	754	162	385	659

$$\boxed{X_4 \quad X_3 \quad X_2 \quad X_1 \quad Y} \equiv F_1 \text{ - RELATIONS}$$

$$F_2 \text{ - RELATIONS} \equiv \boxed{X_5}$$

$$\boxed{X_4 \quad X_3 \quad X_2 \quad X_1 \quad Y}$$